

Kraftfahrzeugverschraubungen

Fittings for air brake systems

KATALOG 411

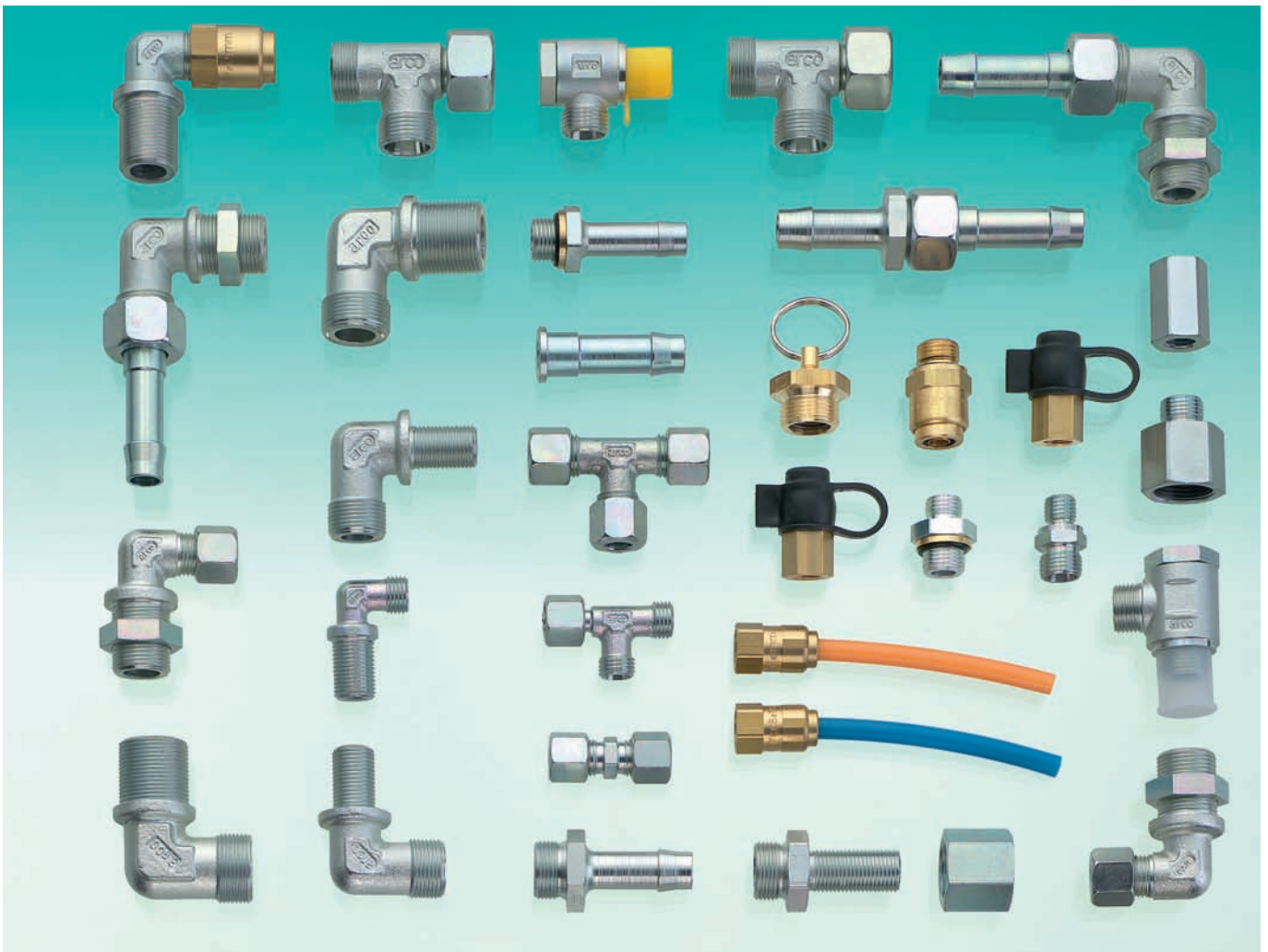

Produktionsprogramm

- **24° Schneidring-und Dichtkegelverschraubungen** mit O-Ring nach DIN EN ISO 8434-1
- **Verschraubungen mit richtungseinstellbaren Anschlüssen** nach DIN EN ISO 6149, ISO 11926 u. a.
- **ORFS-Verschraubungen** (O-ring face seal/ stirnseitiger O-Ringeinstich) mit Anschlüssen nach ISO 8434-3
- **Steckverbinder**
- **Hydrauliksteckverbinder** für Hochdruckanwendungen
- **Druckluftsteckverbinder** für Nutzfahrzeuganwendungen

- **Kraftfahrzeugverschraubungen** nach DIN 74292–74326
- **Prüfanschlüsse**
 - für Druckluftanwendungen
 - für Hydraulikanwendungen
- **Entwässerungsventile** nach DIN 74292

- **Kundenspezifische Zeichnungsteile**
- **Sonderausführungen** (z.B. Sprunggrößen, Drossel-und Lötverschraubungen, Kombinationen unterschiedlicher Anschlußstandards)

manufacturing program

- **24° cone cutting ring couplings and couplings with o-ring** acc. DIN EN ISO 8434-1
- **Couplings with adjustable stud ends** acc. DIN EN ISO 6149, ISO 11926 and others
- **ORFS-couplings** (O-ring-face-seal) with stud ends acc. ISO 8434-3
- **quick couplings**
 - quick couplings for hydraulic high pressure application
 - quick couplings for air brake application

- **Pipe couplings** for air brake systems DIN 74292-74326
- **Test-fittings**
 - for air brake applications
 - for hydraulic high-pressure applications
- **Drain valves** acc. DIN 74292

- **Customer design**
- **Special types** (e.g. jump sizes, throttle and brazed couplings, combination with different coupling standards)

Qualität für eine dauerhafte Verbindung
quality for a good connection

Telefon 0 71 33 / 22 83 347
Fax 0 71 33 / 90 11 461
E-Mail info@prooptimum.de
Homepage www.prooptimum.de

Inhaltsverzeichnis

Seite

Technische Information	
Allgemeine Hinweise	2
Einschraublöcher und Einschraubzapfen	3
Montageanleitungen	4
G/GE-Verbindungsverschraubungen	
GE Gerade Einschraubverschraubungen	8
XGE Gerade Einschraubstützen	10
G/GR Gerade Verschraubungen	11
XG/XGR Gerade Stützen	13
Einstellbare Verschraubungen	
EWA Einstellbare Winkel-Verschraubungen	14
ETA Einstellbare T-Verschraubungen	15
ELA Einstellbare L-Verschraubungen	16
Schwenkverschraubungen	
NS..M/NS..R Schwenkverschraubungen W-Form metrisch/zöllisch	17
Aufschraubverschraubungen	
GA Gerade Aufschraubverschraubungen	18
XGA Gerade Aufschraubstützen	18
W/WE-Verschraubungen	
XWA Winkeleinschraubstützen	19
W W-Verschraubungen	20
XW W-Stützen	21
Schottverschraubungen	
WS- Winkel-Schottverschraubungen	22
XWS Winkel-Schottstützen	23
WE-Verschraubungen	
WE Winkel-Einschraubverschraubungen	24
XWE Winkeleinschraubstützen	25
T/TR-Verschraubungen	
T T-Verschraubungen	26
XT T-Stützen	27
TR/ T T-Reduzierverschraubungen/T-Verschraubungen	28
XT T-Stützen	29
T-Einschraubverschraubungen	
TE T-Einschraubverschraubungen	30
XTE T-Einschraubstützen	32
L-Einschraubverschraubungen	
LE L-Einschraubverschraubungen	33
XLE L-Einschraubstützen	35
K-Einschraubverschraubungen	
K/KE Kreuz-Einschraubverschraubungen	36
XK Kreuzstützen	37
K-Verschraubungen	
K Kreuzverschraubungen	38
XK Kreuzstützen	39
Gerade-Schottverschraubungen	
GS Gerade Schottverschraubungen	40
XGS Gerade Schottstützen	41
T-Schlauchverschraubungen mit Schlauchanschluss	
TSLV T-Schlauchverschraubungen mit Schlauchanschluss	43
W-Schlauchverschraubungen mit Schlauchanschluss	
WSLV W-Schlauchverschraubungen mit Schlauchanschluss	45
Gerade Schlauchverschraubungen	
GSLV Gerade Schlauchverschraubungen	46
Schlauchstützen mit/ohne Gewinde	
SL Schlauchstützen	47
Reduzierstützen	
RSM Reduzierstützen	49
Muffen	
MU Muffen	50
Hohlschrauben	
HS Hohlschraube	51
Sechskantmuttern	
SKM Sechskantmuttern	51
Verschlusschrauben	
VM Verschlusschrauben	52
Überwurfmutter für Schlauchstützen	
M Überwurfmutter für Schlauchstützen	53
Überwurfmuttern	
M Überwurfmuttern	54
Druckringe	
DR Druckringe	55
Schneidringe	
S Schneidringe	56
Druckringe-Rundschnurringe	
DM/RM Druckringe-Rundschnurringe	57
Dichtringe	
FR Dichtringe für STOSS-Verschraubungen	58
Flachdichtringe	
CRM Flachdichtringe für Einschraubzapfen Form A	59
Stützhülsen	
SH Stützhülsen für Kunststoffrohr	60
Entwässerungsventil	
EV Entwässerungsventil	61
Prüfanschlüsse	
M/EM Einschraubprüfanschlüsse	63
Aufschraubprüfanschlüsse	
Gerade Einschraubverschraubungen mit Prüfanschluss	
GE..PA Gerade Einschraubverschraubungen mit Prüfanschluss	64
Gerade Verschraubungen mit Prüfanschluss	
G..PA Gerade Verschraubungen mit Prüfanschluss	65
T-Verschraubungen mit Prüfanschluss	
T..PA Gerade Verschraubungen mit Prüfanschluss	65
Winkel-Verschraubungen mit Prüfanschluss	
WE..PA Winkelverschraubungen mit Prüfanschluss	66

Table of contents

page

Technical information	
General information	2
Threaded plugs and port forms	3
Assembly instructions	4
Straight/straight male couplings	
GE Straight male couplings	8
XGE Straight male coupling body	10
G/GR Straight couplings	11
XG/XGR Straight couplings body	13
Adjustable couplings	
EWA Adjustable male stud elbows	14
ETA Adjustable tee couplings	15
ELA Adjustable run tee couplings	16
Banjo couplings	
NS..M/NS..R Banjo couplings W-Form metric/ BSP	17
Female stud couplings	
GA Straight female couplings	18
XGA Straight female couplings body	18
Elbow couplings	
XWA Elbow couplings	19
W Equal elbows	20
XW Equal elbows body	21
Elbow bulkhead couplings	
WS- Elbow bulkhead couplings	22
XWS Elbow bulkhead couplings body	23
Elbow male couplings	
WE Elbow male couplings	24
XWE Elbow male couplings body	25
Equal tees/reduction tee couplings	
T Equal tees	26
XT Equal tees body	27
TR/ T Tee reduction/tee union	28
XT Equal tees body	29
Tee male couplings	
TE Tee-male couplings	30
XTE Tee-male couplings body	32
Male stud run tee couplings	
LE Male stud run tee couplings	33
XLE Male stud run tee couplings body	35
Cross male couplings	
K/KE Cross male couplings	36
XK Cross male couplings body	37
Cross couplings	
K Cross couplings	38
XK Cross couplings body	39
Bulkhead couplings	
GS Bulkhead couplings	40
XGS Bulkhead couplings body	41
Tee couplings with hose coupling	
TSLV Tee-couplings with hose coupling	43
Elbow couplings with hose coupling	
WSLV Elbow couplings with hose coupling	45
Straight couplings with hose coupling	
GSLV Straight couplings with hose couplings	46
Hose nozzles with/without thread	
SL Hose nozzles	47
Reduction couplings	
RSM Reduction couplings	49
Screw sleeves	
MU Screw sleeves	50
Hollow screws	
HS Hollow screws	51
Lock nuts	
SKM Lock nuts	51
Socket head port plugs	
VM Socket head port plugs	52
Nuts for hose nozzles	
M Nuts for hose nozzles	53
Nuts	
M Nuts	54
Thrustrings	
DR Thrustring	55
Cutting rings	
S Cutting rings	56
Thrustrings-O-Rings	
DM/RM thrustrings/o-rings	57
Sealing washer	
FR Sealing washer	58
Sealing washer	
CRM Sealing washer for stud form A	59
Sleeves	
SH Sleeves for plastic pipes	60
Drainvalves	
EV Drain valves	61
Test set couplings	
M/EM Male test set couplings	63
Female test set couplings	
Straight male couplings with test set couplings	
GE..PA Straight male couplings with test set couplings	64
Straight couplings with test set couplings	
G..PA Straight couplings with test set couplings	65
Tee couplings with test set couplings	
T..PA Tee couplings with test set couplings	65
Elbow couplings with test set couplings	
WE..PA Elbow couplings with test set couplings	66

Allgemeine Hinweise

arco-24° Standard-Rohrverschraubungen für Nutzfahrzeuge werden mit über 50jähriger Erfahrung in der Groß- sowie Kleinserienfertigung hergestellt und weltweit zuverlässig eingesetzt.

Sie entsprechen den gültigen Normen DIN 74313 bis 74319 und der DIN EN ISO 8434-1. Zusätzlich beinhaltet der Katalog noch **arco-24°** Standard-Rohrverschraubungen für Nutzfahrzeuge der zurückgezogenen Normen 74297 bis 74303, sowie Sonderverschraubungen. Sonderausführungen sind in ihren Anschlussmaßen ebenfalls an die Normen angepasst. Um die hohe Leistung und Funktionssicherheit zu gewährleisten, setzt es voraus, dass **arco-24°** Rohrverschraubungskomponenten und **arco-24°** Montageanleitungen eingesetzt werden. Durch technische Weiterentwicklung bedingte Änderungen behalten wir uns vor.

Werkstoffe und Oberflächenschutz

arco-24° Standard-Rohrverschraubungen sind aus gezogenem bzw. geschmiedetem Stahl hergestellt (DIN 3859). Auf Sonderwunsch sind diese auch in Messing bzw. Edelstahl lieferbar. Der Standardoberflächenschutz für Stutzen und Überwurfmutter ist eine spezielle Dickschichtpassivierung. Zusätzlich sind die Überwurfmutter mit einer farblosen Gleitbeschichtung behandelt, um eine gleichbleibende sichere Montagequalität zu gewährleisten.

Selbstverständlich sind zahlreiche weitere Oberflächenvarianten auf Anfrage möglich:

- z.B. **Zink-Eisen**-Dickschichtpassivierung
(Chrom-6 frei)
Zink-Nickel-Dickschichtpassivierung
(Chrom-6-frei)
Zink-Lamellenbeschichtung
(Chrom-6-frei)

Informationen zum Oberflächenschutz:

Die letzten zwei Ziffern bei der Sachnummer oder die zwei letzten Buchstaben in der Artikelnummer dokumentieren bei der Bestellung den Oberflächenschutz des Artikels.

Sachnummer	Artikelnummer	Oberflächenschutz
/21	c3d	spezielle Dickschichtpassivierung (silberfarbig) chrom-6-frei

Druckangaben

24° Schneidring-Rohrsteckanschluss	-LL-Reihe nach DIN 2353 PN 100
Bei Verwendung von Stahlrohr PN (bar)	-L-Reihe nach DIN EN ISO 8434-1 -Rohr-Ø 15 mm PN 315 -Rohr-Ø 22 mm PN 160

24°-Schneidring-Stoßausführung	PN 25
Bei Verwendung von Stahlrohr PN (bar)	

Steck-oder Stoßausführung	- Betriebsdruck nach DIN 73378
Bei Verwendung von Kunststoffrohr	

General Information

arco-24° standard pipe connectors for air brake systems and trucks has been manufactured for more than 50 years in large and small series and are used reliably worldwide.

All parts correspond with the standard DIN 74313 to 74319 and DIN EN ISO 8434-1. Additional the catalog **arco-24°** standard pipe connectors contains the withdrawn standards DIN 74297 to 74303 and special types. Connecting points of special types are also adapted to the valid standards. To guarantee the high performance and operational reliability it is necessary to use the **arco-24°** standard pipe connector components and the **arco-24°** assembly instruction. Further technical development reserved.

Materials and surface treatments

arco-24° pipe connectors are made of drawn or forged steel (according DIN 3859). On request they are also available in brass or stainless steel. The **arco-24°** pipe connectors standard surface treatment of fittings and nuts is a special thickfilm passivation (**chrome-6 free**). Additional all nuts have a antifriction coat for a constant **arco-24°** assembly quality for reducing the torque moments.

On request a lot of alternatives surface treatments are deliverable:

- e.g. **zinc-iron** thickfilm passivation
(chrome-6 free)
zinc-nickel thickfilm passivation
(chrome-6 free)
zinc-flakes thickfilm passivation
(chrome-6 free)

Information for surface treatment:

The last two digits of the computer number or the last two letters of the part number indicate the surface protection.

comp.-No.	part.-No.	Surface Protection
/21	c3d	thick film passivation (silver colored) chrome-6 free

Pressure ratings

arco-24° standard pipe connectors for using steel pipe PN (bar)	-LL-series acc. DIN 2353 -L-series acc. DIN EN ISO 8434-1 -pipe-Ø 15 mm PN 315 -pipe-Ø 22 mm PN 160
--	--

arco-24° standard butt joint connectors for using steel pipe PN (bar)	PN 25
---	-------

arco-24° standard butt joint or push-in connectors for using plastic pipes	working pressure acc. DIN 73378
---	---------------------------------

Einschraubzapfen und Einschraublöcher

Threaded plugs and port forms

ISO-Feingewinde nach DIN 3852 Teil 1 und Teil 11, ISO 9974-1, -2 und -3, Rohrgewinde nach DIN 3852 Teil 2 und Teil 11, ISO 1179-1, -2, -3 und 4
ISO-thread acc. DIN 3852 part 1 and part 11, ISO 9974-1, -2, -3; BSP-thread acc. DIN 3852 part 2 and part 11; ISO 1179-1, -2, -3

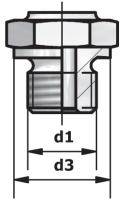

Einschraubzapfen Form A

DIN 3852, Teil 1 und 2
Abdichtung durch
Dichtring DIN 7603

Stud form A

DIN 3852, part 1 and 2
sealing by sealing ring
acc. DIN 7603

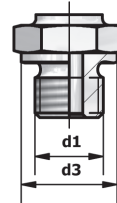

Einschraubzapfen Form B

DIN 3852, Teil 1 und 2
Abdichtung durch Dichtkante /
ISO 9974-3 / ISO 1179-4

Stud form B

DIN 3852, part 1 and 2
metal to metal seal /
acc. ISO 9974-3 / ISO 1179-4

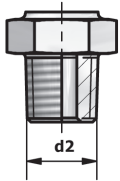

Einschraubzapfen Form C

DIN 3852, Teil 1 und 2
Abdichtung durch
kegeliges Gewinde

Stud form C

DIN 3852, part 1 and 2
Taper thread sealing

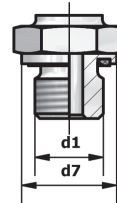

Einschraubzapfen Form E

DIN 3852, Teil 11 /
ISO 9974-2 Abdichtung
durch Dichtring, ISO 1179-2
DIN 3869 / ISO 9974-2 /
ISO 1179-2

Stud form E

DIN 3852, part 11 /
ISO 9974-2 with captive seal
acc. DIN 3869, ISO 9974-2 /
ISO 1179-2

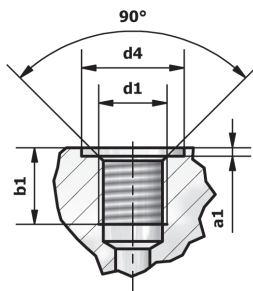

Einschraubloch Form X

DIN 3852, Teil 1 und 2
(nur für zylindrische
Einschraubzapfen)
für Zapfen A, B, E

Port Form X

DIN 3852, part 1 and 2
(Only for cylindric stud form)
for threaded plugs form A, B, E

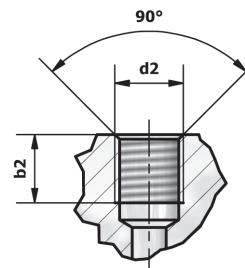

Einschraubloch Form Z

DIN 3852, Teil 1 und 2
(für kegelige Einschraub-
gewinde) für Zapfen C

Port Form Z

DIN 3852, part 1 and 2
(for tapered thread)
for threaded plugs form C

		Form A + B		Form E				Form C	
Reihe Series	Gewinde d1 Thread d1	d3 metr./d3 zöllisch d3 metric/d3 inch	d4 metr./d4 zöllisch d4 metric/d4 inch	d7 metr./d7 zöllisch d7 metric/d7 inch	a1 metr./a1 zöllisch a1 metric/a1 inch	b1 metr./b1 zöllisch b1 metric/b1 inch	Gewinde *d2 Thread *d2	b2 metrisch b2 metric	
LL 4	M8x1 / R1/8keg.	-	-	-	-	-	M8x1keg.	5,5	
LL 6	M10x1 / R1/8keg.	-	-	-	-	-	M8x1keg.	5,5	
LL 8	M10x1 / R1/8keg.	-	-	-	-	-	M8x1keg.	5,5	
L6	M10x1 / G1/8"A	14	15 / 15	13,9	1	8	M10x1keg.	5,5	
L8	M12x1,5 / G1/4"A	17 / 18	18 / 20	16,9 / 18,9	1,5	12	M12x1,5keg.	8,5	
L10	M14x1,5 / G1/4"A	19 / 18	20	18,9	1,5	12	M14x1,5keg.	8,5	
L12	M16x1,5 / G3/8"A	21 / 22	22 / 23	21,9	1,5 / 2	12	M16x1,5keg.	8,5	
L15	M18x1,5 / G1/2"A	23 / 26	24 / 28	23,9 / 26,9	2 / 2,5	12 / 14	M18x1,5keg.	8,5	
L18	M22x1,5 / G1/2"A	27 / 26	28	26,9	2,5	14	M22x1,5keg.	10,5	
L22	M27x2 / G3/4"A	32	33	31,9	2,5	16	-	-	
L28	M33x2 / G1"A	39	40 / 41	39,9	2,5	18	-	-	
L35	M42x2 / G1 1/4"A	49	50 / 51	49,9	2,5	20	-	-	
L42	M48x2 / G1 1/2"A	55	56	54,9	2,5	22	-	-	
S6	M12x1,5 / G1/4"A	17 / 18	18 / 20	16,9 / 18,9	1,5	12	G1/8	5,5	
S8	M14x1,5 / G1/4"A	19 / 18	20	18,9	1,5	12	G1/4	8,5	
S10	M16x1,5 / G3/8"A	21 / 22	22 / 23	21,9	1,5 / 2	12	G3/8	8,5	
S12	M18x1,5 / G3/8"A	23 / 22	24 / 23	23,9 / 21,9	2	12	G1/2	10,5	
S16	M22x1,5 / G1/2"A	27 / 26	28 / 28	26,9	2,5	14	G3/4	13	
S20	M27x2 / G3/4"A	32	33	31,9	2,5	16	-	-	
S25	M33x2 / G1"A	39	40 / 41	39,9	2,5	18	-	-	
S30	M42x2 / G1 1/4"A	49	50 / 51	49,9	2,5	20	-	-	
S38	M48x2 / G1 1/2"A	55	56	54,9	2,5	22	-	-	

* Dichtheit kann nur mit flüssigen oder plastischen Dichtmitteln erreicht werden.
* For a good tightness please use a liquid or plastic jointing compound.

Montageanleitung für arco-Schneidring-Rohrverschraubungen

Direktmontage im Verschraubungsstutzen

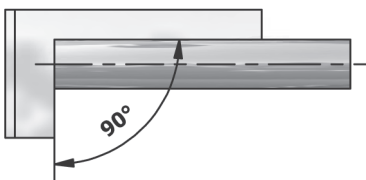
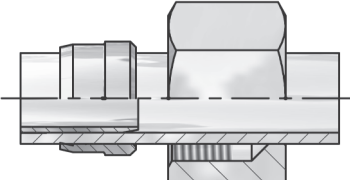
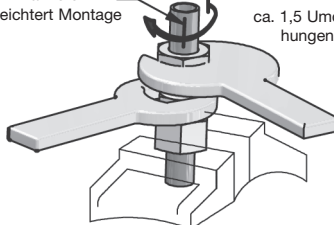
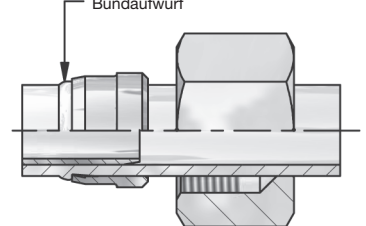
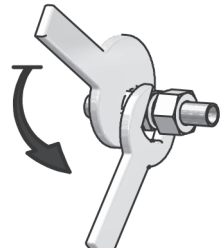
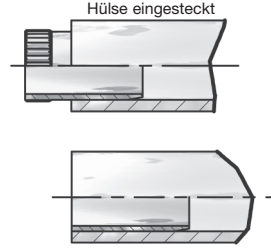
<p>1.</p> 	<p>2.</p> 	<p>3.*</p>  <p>Markieren erleichtert Montage</p> <p>ca. 1,5 Umdrehungen</p>
<p>Rohr rechtwinklig absägen. Max. Winkeltoleranz 0,5°. Rohrabschneider nicht zulässig. Rohrende innen und außen leicht entgraten. Reinigen. Bei dünnwandigen Rohren Verstärkungshülsen verwenden.</p>	<p>Gewinde und Konus der Verschraubungsstutzen sowie Gewinde der Überwurfmutter mit Schmierstoff versehen. Überwurfmutter und Schneidring über Rohrende schieben. Die Schneidringkante muss zum Rohrende zeigen.</p>	<p>Rohr gegen Anschlag im Verschraubungsstutzen drücken, Überwurfmutter von Hand so weit wie möglich aufschrauben. Überwurfmutter mit 1,5 Umdrehungen anziehen.</p>
<p>4.</p>  <p>Bundaufwurf</p>	<p>5.*</p> 	<p>6.*</p>  <p>Hülse eingesteckt</p> <p>Hülse eingeschlagen</p>
<p>Überwurfmutter lösen, prüfen ob der Schneidring eingeschnitten hat. Sichtbarer Bundaufwurf vor der Schneidkante zeigt korrekte Montage an. Der eingeschnittene Schneidring darf sich auf dem Rohr drehen lassen.</p>	<p>Fertig- oder Wiederholmontage. Überwurfmutter nach jedem Lösen ohne erhöhten Kraftaufwand festziehen. Verschraubungsstutzen muss gegengehalten werden.</p>	<p>Hülse bis zum Rändel in das Rohr einstecken. Mit dem Hammer (Kunststoff oder Hartgummi) die Hülse ganz einschlagen. Hierbei presst sich das Rändel in die Rohrwand und sichert die Hülse. Schneidringmontage durchführen. Siehe hierzu Montageanleitung.</p>

3.* Fertigmontage im Verschraubungsstutzen:

Rohr fest gegen Anschlag im Stutzen drücken, dabei die Überwurfmutter um ca. 1½ Umdrehungen mit dem Schlüssel anziehen.

Vormontage im Vormontaggestutzen:

Rohr fest gegen Anschlag drücken, dabei die Überwurfmutter um ca. 1 Umdrehung mit dem Schlüssel anziehen.

Nach der Demontage:

sind die Rohrende in die gleichen Innenkonen des Verschraubungsstutzen einzusetzen, in denen die Montage durchgeführt wurde.

5.* Fertigmontage nach Vormontage:

Bei der Fertigmontage aller vormontierten Teile im dazugehörigen Verschraubungsstutzen muss die Überwurfmutter ca. ¼ Umdrehung über den Punkt des deutlich fühlbaren Kraftanstiegs angezogen werden. Dies gilt auch für Verschraubungen, die werksseitig auf der Schaftseite vormontiert geliefert werden.

6.* Montage von Verstärkungshülsen:

Ist bei den nur nach den Erfordernissen des Innendruckes ausgelegten Rohren die Rohrwanddicke im Verhältnis zum Außendurchmesser des Rohres relativ gering, kann es bei der Montage im Bereich der Einschnittzone von 1-Kant- und 2-Kantschneidring zu stärkeren Rohreinschnürungen kommen. Um dies zu vermeiden, sollten Verstärkungshülsen eingesetzt werden.

Assembly instruction for arco cutting ring fittings

Assembling in the fitting body



<p>1.</p>	<p>2.</p>	<p>3.*</p>
<p>Saw off metal tube square. Max. angletolerance 0,5°. Do not use tube cutters! Deburr inside and outside edge lightly. Clean. For thin-walled tubes please use reinforcing sleeves.</p>	<p>Thread and cone of the union as well as the thread of the nut must be threaded with an lubrication medium. Slip nut and cutting ring on the tube. Ensure that the thicker end of the cutting ring face the nut.</p>	<p>Push the tube against the shoulder in the cone of the body. Then screw nut manually on to the fitting body until fingertight. Tighten nut with spanner 1,5 turns.</p>
<p>4.</p>	<p>5.*</p>	<p>6.*</p>
<p>Loosen nut and check the cut. A visible collar has to fill the space in front of the cutting ring edge. It is no fault if the cutting ring can be rotated on the tube.</p>	<p>Final- or Repeat-assembling. After loosing the nut, tighten again without increased effort. Body to be held firmly by a spanner.</p>	<p>Insert the sleeve into the pipe up to the knurl. Knock in the sleeve completely using a hammer (plastic or hard rubber). The knurl forces itself into the tube wall and secures the sleeve. Do the assembling (look at the assembling instruction in the catalogue).</p>

3.* Final assembling in the body:

Push the tube firmly against shoulder in the cone, tighten nut with spanner about 1,5 turns. The tube must not be rotated.

Pre-assembly in a pre-assembly body:

Push tube firmly against shoulder in the cone, tighten nut with spanner about 1 turn.

After disassembly:

The tube ends have to be inserted in the same cones of the bodies in which the assembly was carried out.

5.* Final assembly of all pre-assembled fittings:

Tighten nut about ¼ turn beyond the point of a clearly perceptible resistance. This is valid as well for all pre-assembled fittings delivered by the manufacturer.

6.* Assembling with reinforcing sleeve:

If due the requirements of the internal pressure the wall thickness in relation to the external is too low, there can be constrictions of the tube. To avoid this reinforcing sleeves should be used.

Montage mit Verstärkungshülsen

Assembling with reinforcing sleeves

Tab. 1

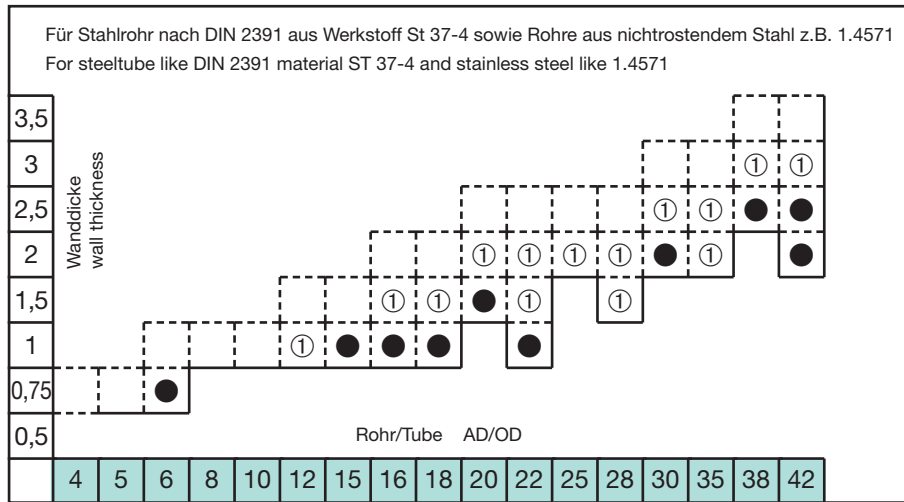

Tab. 2

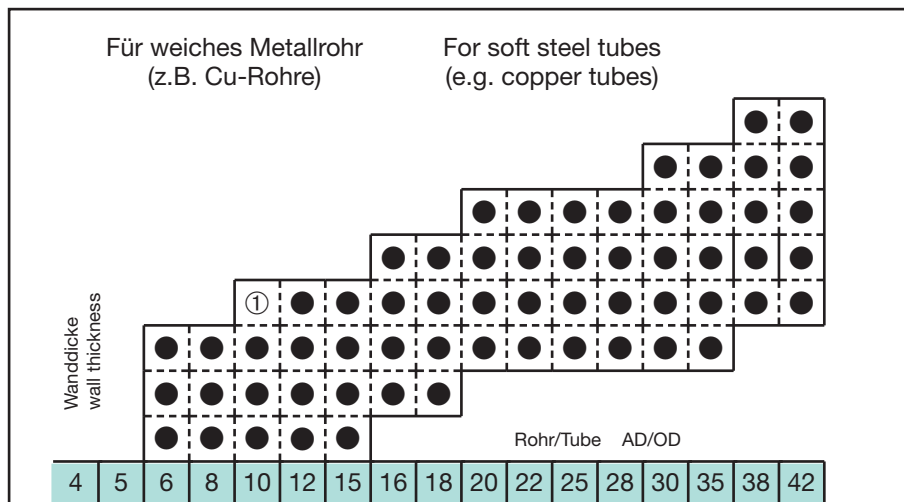

● VH unbedingt erforderlich

① VH erforderlich bei öfterem Lösen und stark beanspruchten Leitungen (Schwingungen)

● Reinforcing sleeve definitely necessary

① Reinforcing sleeve necessary if high repetition assembling rate and heavy loaded pipes (loading by vibration)

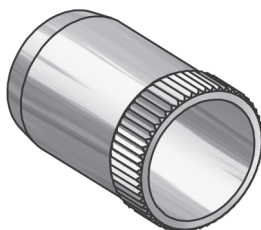

Verstärkungshülse
reinforcing sleeve

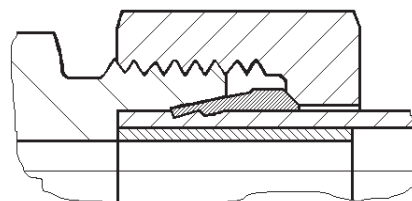

Mit Verstärkungshülse montiert
Assembled with reinforcing sleeve

Assembly instructions for arco fittings butt joint type

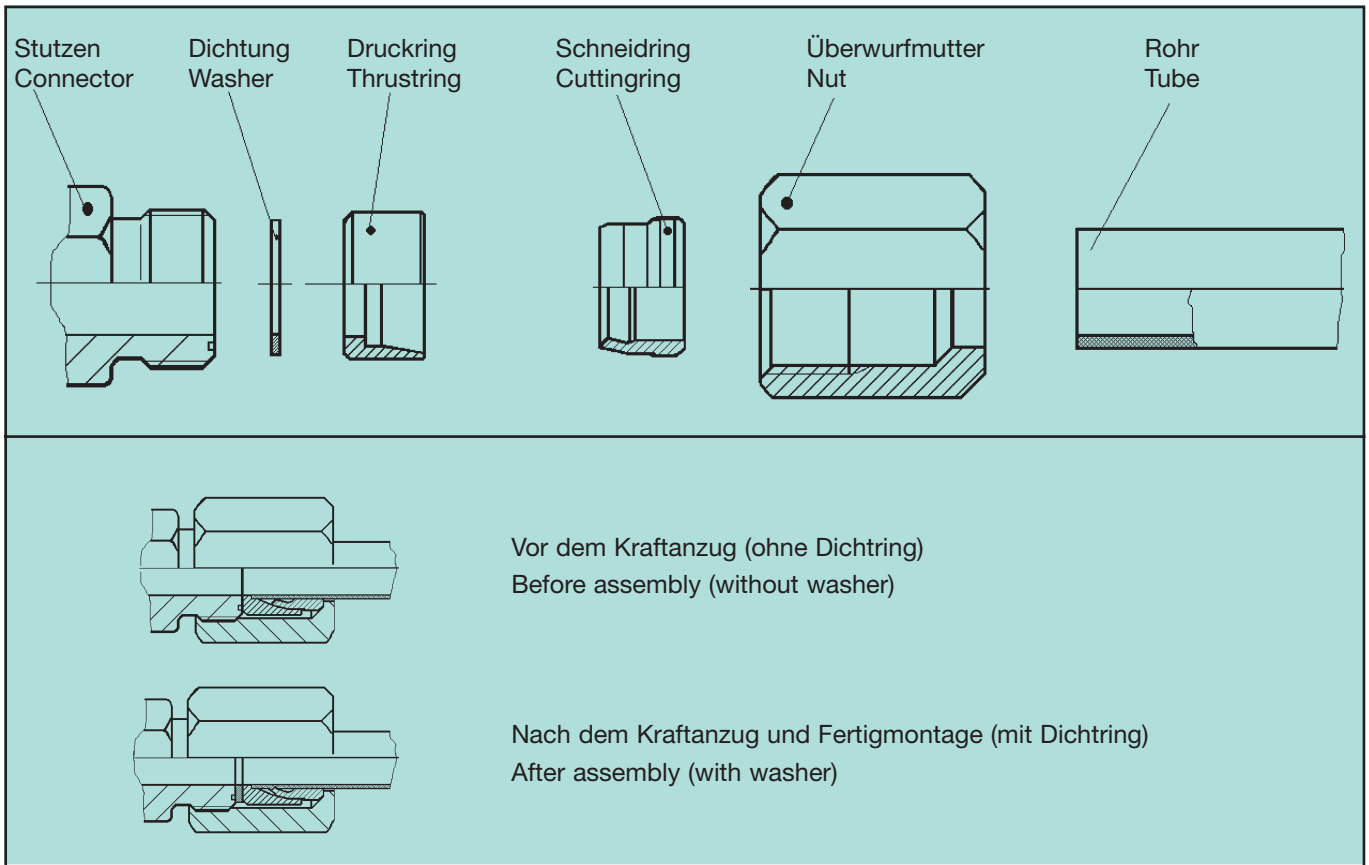

- | | |
|---|--|
| <ol style="list-style-type: none"> 1. Metallrohr rechtwinklig absägen sowie innen und außen entgraten.
Keine Rohrabschneider verwenden. 2. Überwurfmuttergewinde, Schneidring und Druckring leicht einölen. 3. Überwurfmutter und Schneidring auf das Rohr schieben. Die Schneidringkante muss in Richtung Rohrende zeigen. 4. Verschraubung ohne Dichtring zusammenbauen, das Rohr gegen den Anschlag im Druckring drücken und die Überwurfmutter soweit wie möglich von Hand aufschrauben, nun mit dem Schraubenschlüssel 1½ Umdrehungen anziehen. 5. Überwurfmutter lösen und prüfen, ob der Schneidring eingeschnitten hat. Es muss ein sichtbarer Bund vor der Schneidringkante entstanden sein. 6. Anschließend die Verschraubung wieder komplettieren, hierbei jedoch den Dichtring zwischen Stutzen und Druckring einlegen. Danach Überwurfmutter mit dem Schraubenschlüssel ca. ¼ Umdrehung über den spürbaren Kraftanstieg anziehen. 7. Nach der Endmontage kann die Verschraubung nach jedem Lösen ohne erhöhten Kraftaufwand wieder festgezogen werden. 8. Bei der Verwendung von dünnwandigen und weichem Metallrohr sowie Kunststoffrohr ist eine Verstärkungshülse zu verwenden. Diese verhindert bei der Schneidmontage (Stoß-Steckmontage) die Rohreinschnürung im Schneidbereich. | <ol style="list-style-type: none"> 1. Saw off metal tube square and deburr inside and outside edge. Do not use tube cutter! 2. Oil tread of nut also cutting ring and the cone of the thrusting. 3. Slip nut and cutting ring on the tube. Ensure that the thicker end faces the nut. 4. Assemble fitting without sealing ring. Push the tube against the shoulder in the thrust-ring and screw the nut manually until fingertight, now tighten nut with spanner about 1½ turns. 5. Loosen nut and check the cut. A visible collar has to fill the space in the front of the cutting ring edge. 6. Then assemble the fitting again, but insert now the sealing ring between thrust-ring and body. Then tighten nut with spanner about ¼ turn beyond the point of the plain perceptible resistance. 7. After final assembling the fitting can be tightened again without increased effort. 8. In case of using thin wall tubes or nylon tubes a reinforced sleeve has to be taken. This avoids constrictions of the tube. |
|---|--|

Gerade Einschraubverschraubungen

Straight male couplings

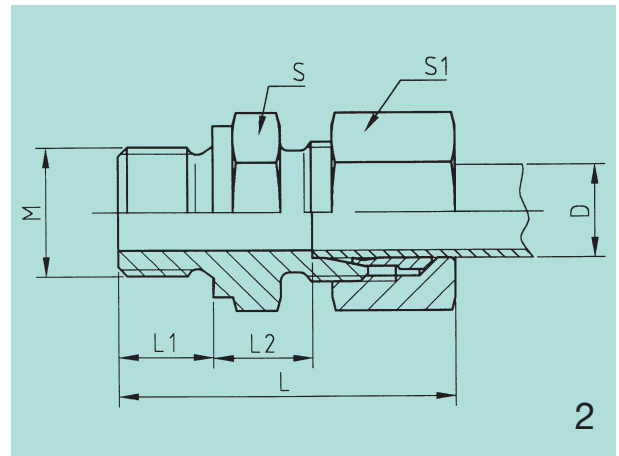
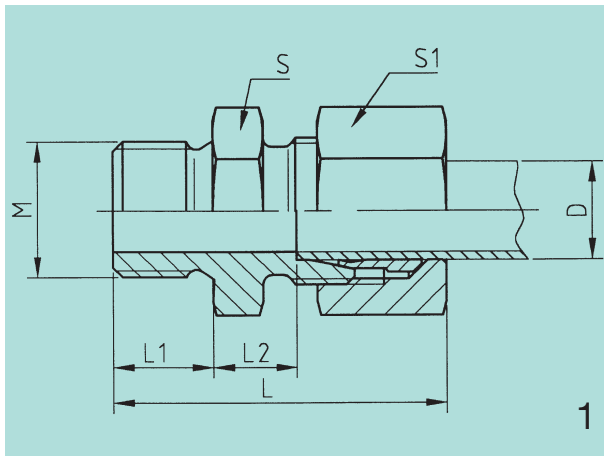

D	M	L	L ₁	L ₂	S	S ₁	Bild pic.	Sach.-Nr. comp. no.	Artikel-Nr. part no.
6	10x1	31	8	8,5	14	14	2	2800/21	GE6M10ZLFAc3d
6	12x1,5	36	12	10	17	14	2	2801/21	GE6M12ZLFAc3d
6	14x1,5	36	12	10	19	14	2	2802/21	GE6M14ZLFAc3d
6	16x1,5	36	12	9	22	14	1	2803/21	GE6M16D27c3d
6	22x1,5	36	12	9	27	14	1	2804/21	GE6M22D27c3d
6	G1/8A	31	8	8,5	14	14	2	2805/21	GE6R1/8ZLFAc3d
8	12x1,5	37	12	10	17	17	2	2806/21	GE8M12ZLFAc3d
8	14x1,5	37	12	10	19	17	2	2807/21	GE8M14ZLFAc3d
8	14x1,5	36	12	9	19	17	1	3125/21	GE8M14D27c3d
8	16x1,5	36	12	9	22	17	1	2808/21	GE8M16D27c3d
8	22x1,5	36	12	9	27	17	1	2809/21	GE8M22D27c3d
8	G1/4A	37	12	10	19	17	2	2810/21	GE8R1/4ZLFAc3d
10	12x1,5	38	10	11	19	19	1	2811/21	GE10M12D27c3d
10	12x1,5	38	12	11	17	19	2	2812/21	GE10M12ZLFAc3d
10	14x1,5	38	12	11	19	19	2	2813/21	GE10M14ZLFAc3d
10	16x1,5	38	12	12,5	22	19	2	2814/21	GE10M16ZLFAc3d
10	18x1,5	38	12	12,5	24	19	2	2816/21	GE10M18ZLFAc3d
10	22x1,5	38	12	10	27	19	1	2818/21	GE10M22D27c3d
10	G1/4A	38	12	11	19	19	2	2819/21	GE10R1/4ZLFAc3d
12	12x1,5	36	10	11	19	22	1	3109/21	GE12M12Dc3d
12	14x1,5	39	12	12,5	19	22	2	3114/21	GE12M14ZLFAc3d
12	16x1,5	39	12	12,5	22	22	2	2820/21	GE12M16ZLFAc3d
12	18x1,5	39	12	12,5	24	22	2	2821/21	GE12M18ZLFAc3d
12	22x1,5	39	12	10	27	22	1	2822/21	GE12M22D27c3d
12	G3/8A	39	12	12,5	22	22	2	2823/21	GE12R3/8ZLFAc3d
15	16x1,5	48	12	10	24	27	1	2824/21	GE15M16Dc3d
15	16x1,5	48	12	13,5	24	27	2	3108/21	GE15M16ZLFAc3d
15	18x1,5	48	12	13,5	24	27	2	2828/21	GE15M18ZLFAc3d
15	22x1,5	41	12	15	27	27	2	2829/21	GE15M22ZLFAc3d
15	G1/2A	43	14	14	27	27	2	2832/21	GE15R1/2ZLFAc3d
16	22x1,5	48	12	11	27	27	1	3113/21	GE16M22Dc3d
16	26x1,5	48	12	11	32	27	1	3112/21	GE16M26Dc3d
18	22x1,5	45	14	14,5	27	32	2	2835/21	GE18M22ZLFAc3d
18	G1/2A	45	14	14,5	27	32	2	2838/21	GE18R1/2ZLFAc3d
22	26x1,5	49	16	16,5	32	36	2	2839/21	GE22M26ZLFAc3d
22	G3/4A	49	16	16,5	32	36	2	3132/21	GE22R3/4ZLFAc3d

Gerade Einschraubverschraubungen

Straight male couplings

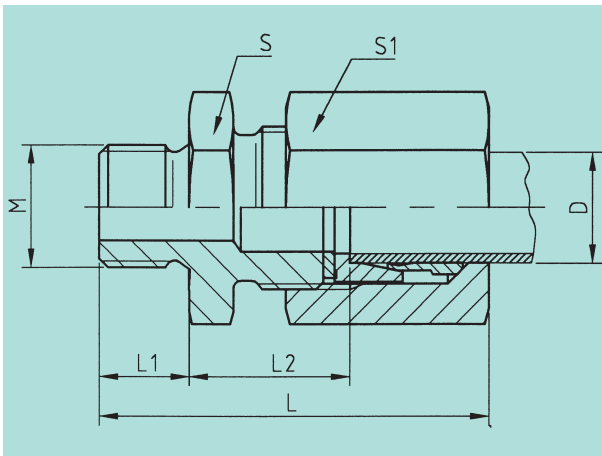

D	M	L	L ₁	L ₂	S	S ₁	Sach.-Nr. comp. no.	Artikel-Nr. part no.
D	M	L	L ₁	L ₂	S	S ₁		
10	18x1,5	49	12	21,5	22	22	2815/21	GE10M18D98c3d
10	22x1,5	49	12	21,5	27	22	2817/21	GE10M22D99c3d
15	22x1,5	49	12	21,5	27	27	2830/21	GE15M22D99c3d
15	26x1,5	49	12	21,5	32	27	2831/21	GE15M26D99c3d
15	G1/2A	49	12	21,5	27	27	3101/21	GE15R1/2D98c3d
16	22x1,5	49	12	21,5	27	27	2833/21	GE16M22D98c3d
16	26x1,5	49	12	21,5	32	27	2834/21	GE16M26D98c3d
18	22x1,5	49	12	21,5	32	32	2836/21	GE18M22D99c3d
18	26x1,5	49	12	21,5	32	32	2837/21	GE18M26D98c3d

Gerade Einschraubstutzen

Straight male connectors

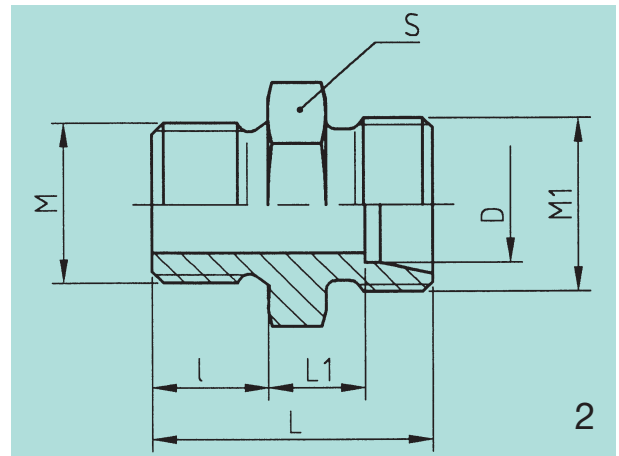
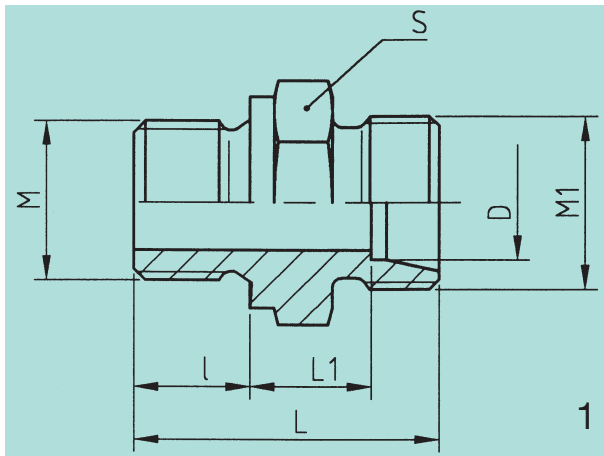

D	l	L	L ₁	S	M	M _i	Bild pic.	Sach.-Nr. comp. no.	Artikel-Nr. part no.
6	8	23,5	8,5	14	10x1	12x1,5	1	2200/21	XGE6M10ZLFAc3d
6	12	29	10	17	12x1,5	12x1,5	1	2201/21	XGE6M12ZLFAc3d
6	12	29	10	19	14x1,5	12x1,5	1	2202/21	XGE6M14ZLFAc3d
6	12	28	9	22	16x1,5	12x1,5	2	2203/21	XGE6M16D13c3d
6	12	28	9	27	22x1,5	12x1,5	2	2204/21	XGE6M22D13c3d
6	8	23,5	8,5	14	G1/8A	12x1,5	1	2205/21	XGE6R1/8ZLFAc3d
8	12	29	10	17	12x1,5	14x1,5	1	2206/21	XGE8M12ZLFAc3d
8	12	29	10	19	14x1,5	14x1,5	1	2207/21	XGE8M14ZLFAc3d
8	12	28	9	19	14x1,5	14x1,5	2	2601/21	XGE8M14D13c3d
8	12	28	9	22	16x1,5	14x1,5	2	2208/21	XGE8M16D13c3d
8	12	28	9	27	22x1,5	14x1,5	2	2209/21	XGE8M22D13c3d
8	12	29	10	19	G1/4A	14x1,5	1	2210/21	XGE8R1/4ZLFAc3d
10	12	30	11	17	12x1,5	16x1,5	1	2212/21	XGE10M12ZLFAc3d
10	12	30	11	19	14x1,5	16x1,5	1	2213/21	XGE10M14ZLFAc3d
10	12	31,5	12,5	22	16x1,5	16x1,5	1	2214/21	XGE10M16ZLFAc3d
10	12	31,5	12,5	24	18x1,5	16x1,5	1	2215/21	XGE10M18ZLFAc3d
10	10	28	11	19	12x1,5	16x1,5	2	2211/21	XGE10M12D13c3d
10	12	29	10	27	22x1,5	16x1,5	2	2216/21	XGE10M22D13c3d
10	12	30	11	19	G1/4A	16x1,5	1	2217/21	XGE10R1/4ZLFAc3d
10	12	31,5	12,5	22	G3/8A	16x1,5	1	2218/21	XGE10R3/8ZLFAc3d
12	12	31,5	12,5	19	14x1,5	18x1,5	1	2221/21	XGE12M14ZLFAc3d
12	12	31,5	12,5	22	16x1,5	18x1,5	1	2222/21	XGE12M16ZLFAc3d
12	12	31,5	12,5	24	18x1,5	18x1,5	1	2220/21	XGE12M18ZLFAc3d
12	10	28	11	19	12x1,5	18x1,5	2	2219/21	XGE12M12D13c3d
12	12	29	10	27	22x1,5	18x1,5	2	2224/21	XGE12M22D13c3d
12	12	31,5	12,5	22	G3/8A	18x1,5	1	2225/21	XGE12R3/8ZLFAc3d
15	12	32,5	13,5	24	16x1,5	22x1,5	1	2227/21	XGE15M16ZLFAc3d
15	12	32,5	13,5	24	18x1,5	22x1,5	1	2228/21	XGE15M18ZLFAc3d
15	14	36	15	27	22x1,5	22x1,5	1	2229/21	XGE15M22ZLFAc3d
15	12	29	10	24	16x1,5	22x1,5	2	2226/21	XGE15M16Dc3d
15	14	32,5	14	27	G1/2A	22x1,5	1	2230/21	XGE15R1/2ZLFAc3d
18	14	36	14,5	27	22x1,5	26x1,5	1	2231/21	XGE18M22ZLFAc3d
18	14	36	14,5	27	G1/2A	22x1,5	1	2232/21	XGE18R1/2ZLFAc3d
22	16	40	16,5	32	26x1,5	30x2	1	2233/21	XGE22M26ZLFAc3d
22	16	40	16,5	32	G3/4A	30x2	1	2587/21	XGE22R3/4ZLFAc3d

Straight couplings

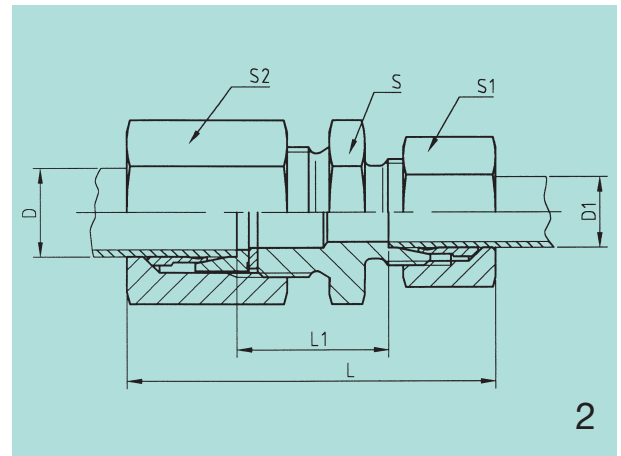
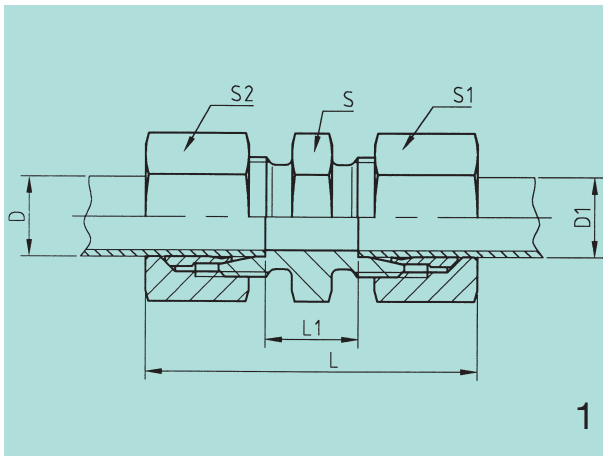

D	D ₁	L	L ₁	S	S ₁	S ₂	Bild pic.	Sach.-Nr. comp. no.	Artikel-Nr. part no.
6	6	41	12	17	14	14	1	2840/21	G6D98c3d
6	6	39	10	12	14	14	1	1280/21	G6Lc3d
8	6	40	11	14	14	17	1	1303/21	GR8/6Lc3d
8	8	40	11	14	17	17	1	1281/21	G8Lc3d
10	6	42	12	17	14	19	1	1304/21	GR10/6Lc3d
10	8	42	12	17	17	19	1	1305/21	GR10/8Lc3d
10	10	42	13	17	19	19	1	1283/21	G10Lc3d
12	6	43	13	19	14	22	1	1307/21	GR12/6Lc3d
12	8	43	13	19	17	22	1	1308/21	GR12/8Lc3d
12	10	43	14	19	19	22	1	1309/21	GR12/10Lc3d
12	12	43	14	19	22	22	1	1284/21	G12Lc3d
15	6	55	24	27	14	27	2	2842/21	GR15/6D13c3d
15	8	55	24	27	17	27	2	2843/21	GR15/8D13c3d
15	10	56	25	27	19	27	2	2845/21	GR15/10D13c3d
15	12	56	25	27	22	27	2	2846/21	GR15/12D13c3d
15	15	46	16	24	27	27	1	1285/21	G15Lc3d
16	16	46	16	27	27	27	1	2848/21	G16Dc3d
18	18	48	16	27	32	32	1	1287/21	G18Lc3d
22	22	52	20	32	36	36	1	1288/21	G22Lc3d

Gerade Verschraubungen

Straight couplings

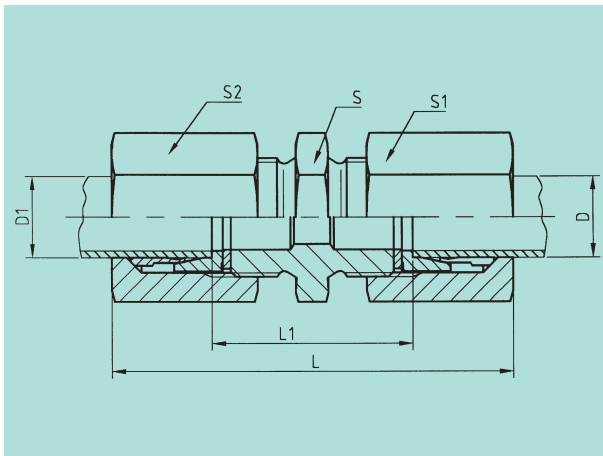

D	D ₁	L	L ₁	S	S ₁	S ₂	Sach.-Nr. comp. no.	Artikel-Nr. part no.
15	15	68	37	27	27	27	2847/21	G15D98c3d
16	16	68	37	27	27	27	2849/21	G16D27c3d
18	15	68	37	32	32	27	2850/21	GR18/15D99c3d
18	18	68	37	32	32	32	2851/21	G18D98c3d

Straight couplings

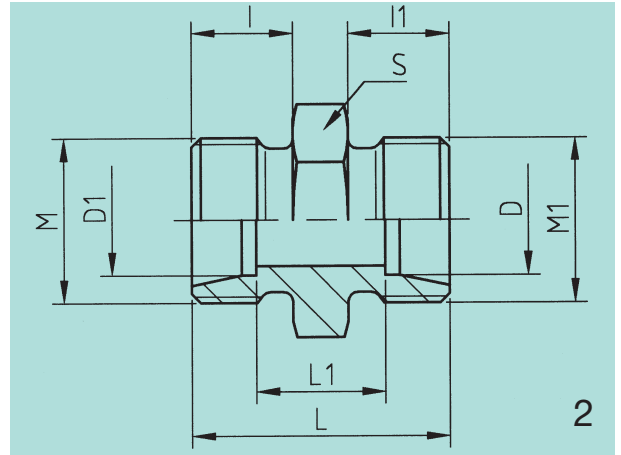
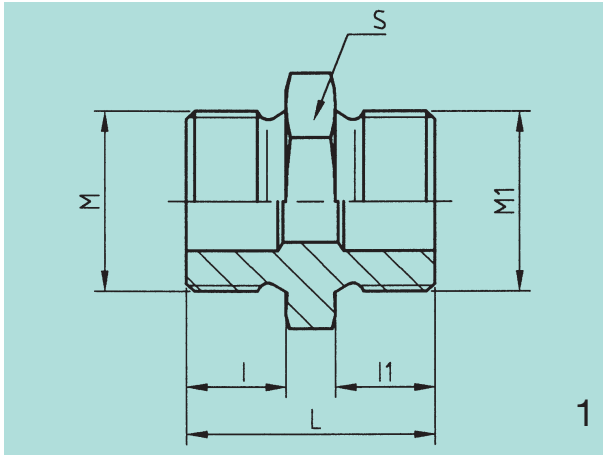

D	D ₁	I	I ₁	L	L ₁	S	M	M ₁	Bild pic.	Sach.-Nr. comp. no.	Artikel-Nr. part no.
6	6	10	10	26	12	17	12x1,5	12x1,5	2	2235/21	XG6D98c3d
6	6	10	10	24	10	12	12x1,5	12x1,5	2	276/21	XG6Lc3d
8	8	10	10	25	11	14	14x1,5	14x1,5	2	278/21	XG8Lc3d
8	6	10	10	25	11	14	12x1,5	14x1,5	2	301/21	XGR8/6Lc3d
10	10	11	11	27	13	17	16x1,5	16x1,5	2	279/21	XG10Lc3d
10	6	10	11	26	12	17	12x1,5	16x1,5	2	302/21	XGR10/6Lc3d
10	8	10	11	26	12	17	14x1,5	16x1,5	2	303/21	XGR10/8Lc3d
12	12	11	11	28	14	19	18x1,5	18x1,5	2	280/21	XG12Lc3d
12	6	10	11	27	13	19	12x1,5	18x1,5	2	305/21	XGR12/6Lc3d
12	8	10	11	27	13	19	14x1,5	18x1,5	2	306/21	XGR12/8Lc3d
12	10	11	11	28	14	19	16x1,5	18x1,5	2	307/21	XGR12/10Lc3d
15	15	12	12	30	16	24	22x1,5	22x1,5	2	282/21	XG15Lc3d
15	8	10	12	28	14	24	14x1,5	22x1,5	2	308/21	XGR15/8Lc3d
15	10	11	12	29	15	24	16x1,5	22x1,5	2	309/21	XGR15/10Lc3d
15	12	11	12	29	15	24	18x1,5	22x1,5	2	310/21	XGR15/12Lc3d
-	-	12	12	30	-	27	22x1,5	22x1,5	1	2238/21	XG15D98c3d
-	-	12	12	30	-	27	16x1,5	22x1,5	1	2583/21	XGE15M16D98c3d
-	-	12	12	30	-	27	G1/2A	22x1,5	1	2576/21	XGE15R1/2D98c3d
16	16	12	12	30	16	27	22x1,5	22x1,5	2	2239/21	XG16Dc3d
-	-	12	12	30	-	27	22x1,5	22x1,5	1	2241/21	XGEB16M22D13c3d
-	-	12	12	30	-	32	26x1,5	22x1,5	1	2243/21	XGEB16M26D13c3d
18	18	12	12	31	16	27	26x1,5	26x1,5	2	284/21	XG18Lc3d
-	-	12	12	30	-	32	26x1,5	26x1,5	1	2242/21	XG18D98c3d
-	-	12	12	30	-	32	22x1,5	26x1,5	1	2240/21	XGE18D99c3d
22	22	14	14	35	20	32	30x2	30x2	2	285/21	XG22Lc3d

Einstellbare Winkel-Anschlüsse

Adjustable male stud elbows

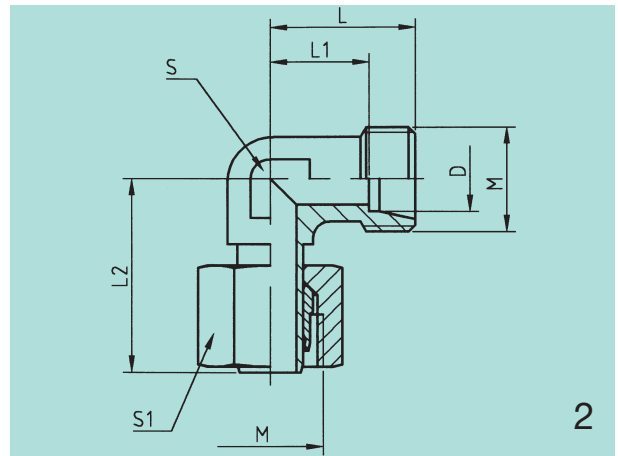
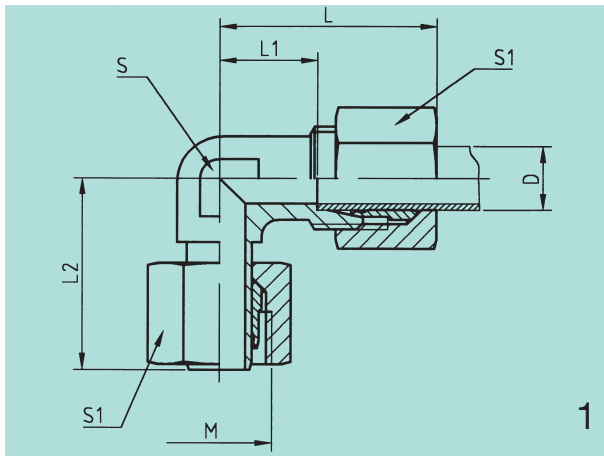

D	L	L ₁	L ₂	S	S ₁	M	Bild pic.	Sach.-Nr. comp. no.	Artikel-Nr. part no.
6	27	12	26	12	14	12x1,5	1	1765/21	EWA6Lc3d
8	29	14	27,5	12	17	14x1,5	1	1767/21	EWA8Lc3d
10	30	15	29	14	19	16x1,5	1	1768/21	EWA10Lc3d
12	32	17	29,5	17	22	18x1,5	1	1770/21	EWA12Lc3d
15	36	21	32,5	19	27	22x1,5	1	1771/21	EWA15Lc3d
18	40	24	35,5	24	32	26x1,5	1	1773/21	EWA18Lc3d
22	44	28	38,5	27	36	30x2	1	1774/21	EWA22Lc3d
6	19	12	26	12	14	12x1,5	2	1789/21	XEWA6Lc3d
8	21	14	27,5	12	17	14x1,5	2	1791/21	XEWA8Lc3d
10	22	15	29	14	19	16x1,5	2	1792/21	XEWA10Lc3d
12	24	17	29,5	17	22	18x1,5	2	1794/21	XEWA12Lc3d
15	28	21	32,5	19	27	22x1,5	2	1795/21	XEWA15Lc3d
18	31	23,5	35,5	24	32	26x1,5	2	1796/21	XEWA18Lc3d
22	35	28	38,5	27	36	30x2	2	1797/21	XEWA22Lc3d

* siehe Allgemeine Hinweise
* see General Information

Einstellbare T-Anschlüsse

Adjustable tee couplings

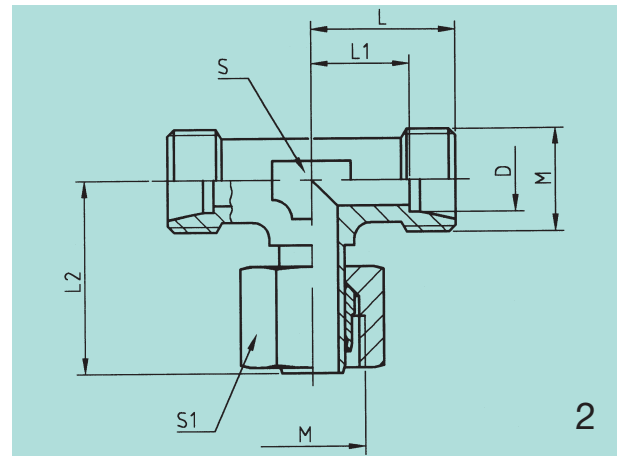
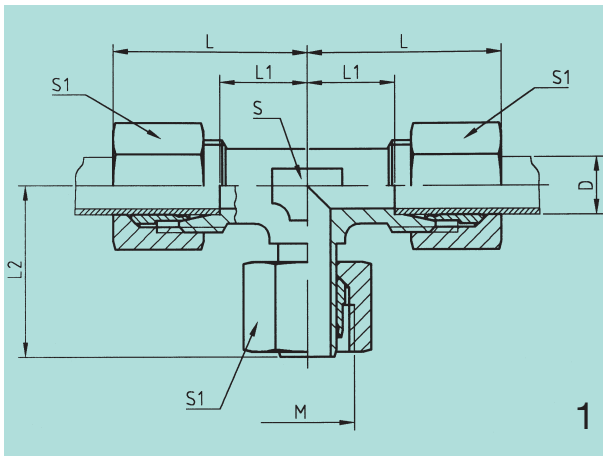

D	L	L ₁	L ₂	S	S ₁	M	Bild pic.	Sach.-Nr. comp. no.	Artikel-Nr. part no.
6	27	12	26	12	14	12x1,5	1	1834/21	ETA6Lc3d
8	29	14	27,5	12	17	14x1,5	1	1835/21	ETA8Lc3d
10	30	15	29	14	19	16x1,5	1	1836/21	ETA10Lc3d
12	32	17	29,5	17	22	18x1,5	1	1837/21	ETA12Lc3d
15	36	21	32,5	19	27	22x1,5	1	1838/21	ETA15Lc3d
18	40	24	35,5	24	32	26x1,5	1	1839/21	ETA18Lc3d
22	44	28	38,5	27	36	30x2	1	1840/21	ETA22Lc3d
6	19	12	26	12	14	12x1,5	2	1854/21	XETA6Lc3d
8	21	14	27,5	12	17	14x1,5	2	1855/21	XETA8Lc3d
10	22	15	29	14	19	16x1,5	2	1856/21	XETA10Lc3d
12	24	17	29,5	17	22	18x1,5	2	1857/21	XETA12Lc3d
15	28	21	32,5	19	27	22x1,5	2	1858/21	XETA15Lc3d
18	31	23,5	35,5	24	32	26x1,5	2	1859/21	XETA18Lc3d
22	35	28	38,5	27	36	30x2	2	1860/21	XETA22Lc3d

Einstellbare L-Anschlüsse

Adjustable run tee couplings

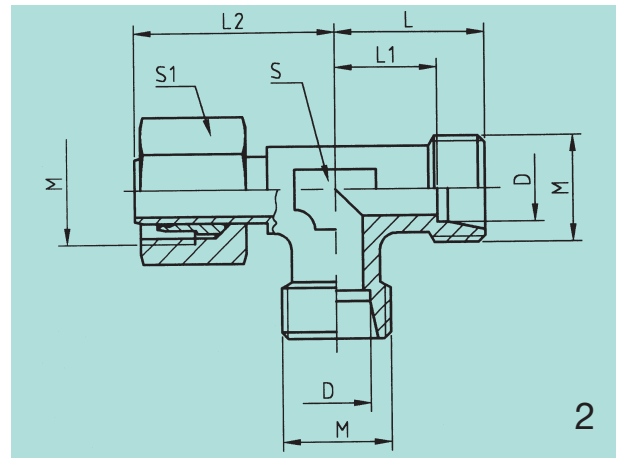
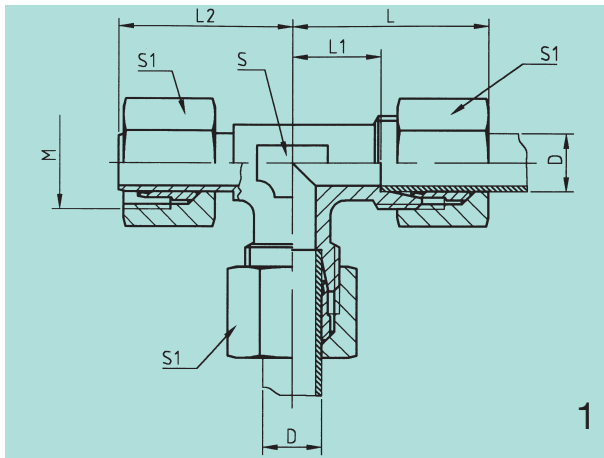

D	L	L ₁	L ₂	S	S ₁	M	Bild pic.	Sach.-Nr. comp. no.	Artikel-Nr. part no.
6	27	12	26	12	14	12x1,5	1	1894/21	ELA6Lc3d
8	29	14	27,5	12	17	14x1,5	1	1895/21	ELA8Lc3d
10	30	15	29	14	19	16x1,5	1	1896/21	ELA10Lc3d
12	32	17	29,5	17	22	18x1,5	1	1897/21	ELA12Lc3d
15	36	21	32,5	19	27	22x1,5	1	1898/21	ELA15Lc3d
18	40	24	35,5	24	32	26x1,5	1	1900/21	ELA18Lc3d
22	44	28	38	27	36	30x2	1	1901/21	ELA22Lc3d
6	19	12	26	12	14	12x1,5	2	1915/21	XELA6Lc3d
8	21	14	27,5	12	17	14x1,5	2	1916/21	XELA8Lc3d
10	22	15	29	14	19	16x1,5	2	1917/21	XELA10Lc3d
12	24	17	29,5	17	22	18x1,5	2	1918/21	XELA12Lc3d
15	28	21	32,5	19	27	22x1,5	2	1919/21	XELA15Lc3d
18	31	23,5	35,5	24	32	26x1,5	2	1920/21	XELA18Lc3d
22	35	28	38,5	27	36	30x2	2	1921/21	XELA22Lc3d

Banjo couplings

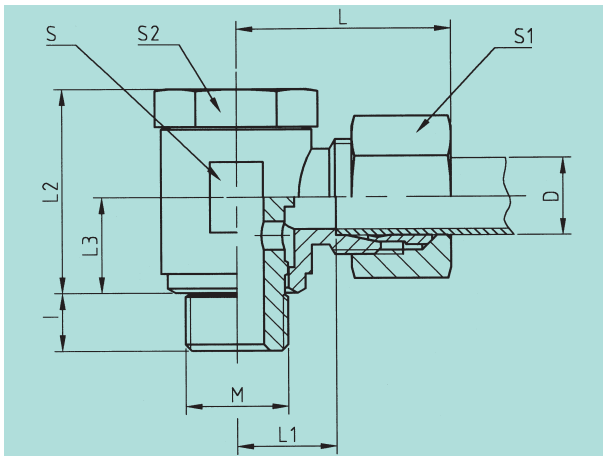

D	I	L	L ₁	L ₂	L ₃	S	S ₁	S ₂	M	Sach.-Nr. comp. no.	Artikel-Nr. part no.
6	6	25	11	22	10	14	14	14	10x1	1716/21	NS6M10Lc3d
8	9	27	12	25	12	17	17	17	12x1,5	1717/21	NS8M12Lc3d
10	9	29	14	27	13	19	19	19	14x1,5	1719/21	NS10M14Lc3d
12	9	30	16	32	15	22	22	22	16x1,5	1721/21	NS12M16Lc3d
15	9	33	18	38	18	24	27	24	18x1,5	1723/21	NS15M18Lc3d
6	6	25	11	22	10	14	14	14	G1/8A	1686/21	NS6R1/8Lc3d
8	9	28	13	27	13	19	17	19	G1/4A	1687/21	NS8R1/4Lc3d
10	9	29	14	27	13	19	19	19	G1/4A	1688/21	NS10R1/4Lc3d
12	9	30	16	32	15	22	22	22	G3/8A	1689/21	NS12R3/8Lc3d
15	9	34	19	37	17	27	27	27	G1/2A	1690/21	NS15R1/2Lc3d

Ausführung bis 15 mm Rohraußendurchmesser mit angedrehter Dichtkante gefertigt
 Design up to 15 mm tube outdiameter with sealing edge manufactured

Gerade Aufschraubverschraubungen

Straight female couplings

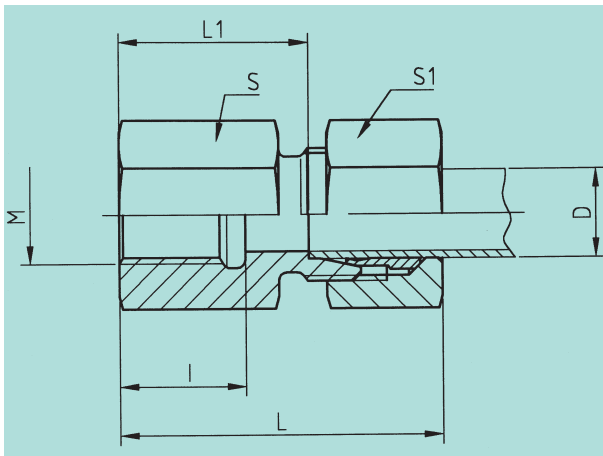

D	M	I	L	L ₁	S	S ₁	Sach.-Nr. comp. no.	Artikel-Nr. part no.
D	M	I	L	L ₁	S	S ₁		
6	22x1,5	14	37	30	27	14	3001/21	GA6M22Lc3d
8	22x1,5	14	37	30	27	17	3002/21	GA8M22Lc3d
10	22x1,5	14	38	31	27	19	3003/21	GA10M22Lc3d
12	22x1,5	14	38	31	27	22	3004/21	GA12M22Lc3d

Gerade Aufschraubstutzen

Straight female couplings

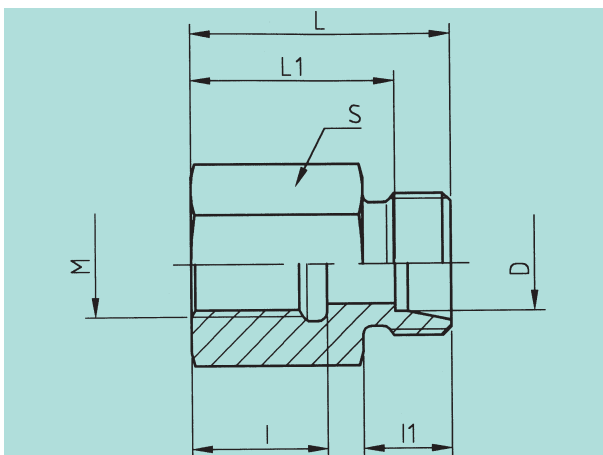

D	I	I ₁	L	L ₁	S	M	Sach.-Nr. comp. no.	Artikel-Nr. part no.
D	I	I ₁	L	L ₁	S	M		
6	14	10	30	23	27	22x1,5	2372/21	XGA6M22Lc3d
8	14	10	30	23	27	22x1,5	2373/21	XGA8M22Lc3d
10	14	11	31	24	27	22x1,5	2374/21	XGA10M22Lc3d
12	14	11	31	24	27	22x1,5	2375/21	XGA12M22Lc3d

Winkel-Einschraubstutzen

Elbows couplings

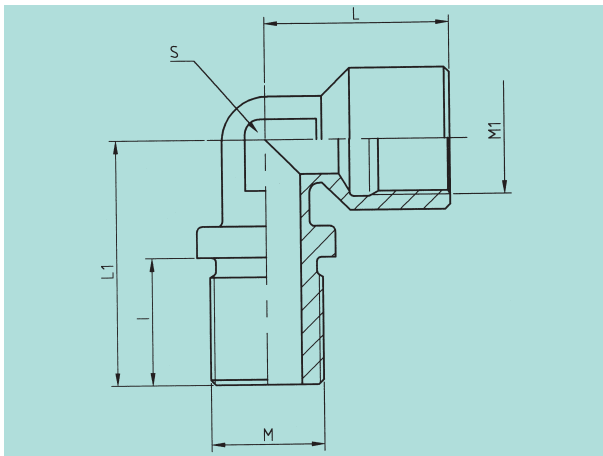

I	L	L ₁	S	M	M ₁	Sach.-Nr.	Artikel-Nr.
I	L	L ₁	S	M	M ₁	comp. no.	part no.
25	36	48	19	22x1,5	22x1,5	2274/21	XWA15M22D01c3d
25	36	48	19	22x1,5	22x1,5	2613/21	XWA15M22D15c3d

Alle Stutzen auch mit Sechskantmutter lieferbar: Artikelnummer + SM
 Supplied as well with lock nut: part no. + SM

Winkel-Verschraubungen

Equal elbows

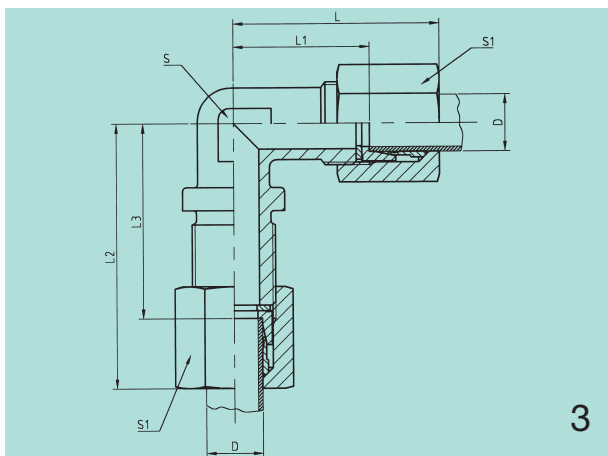
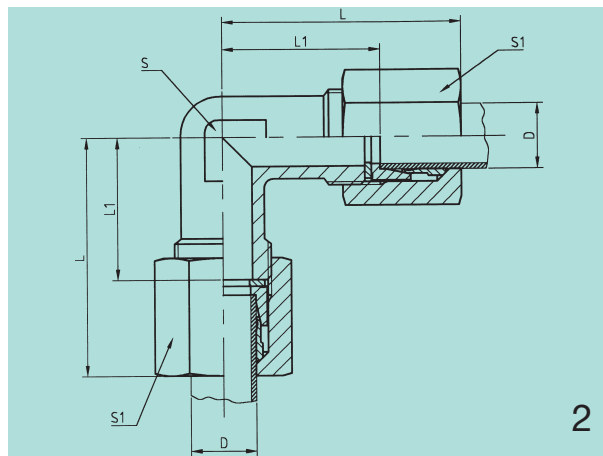
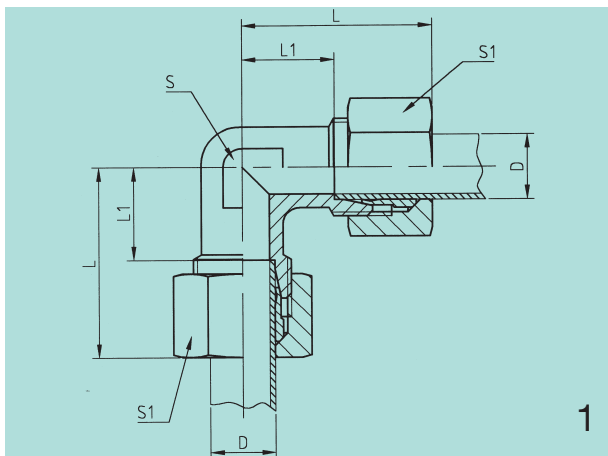

D	L	L ₁	L ₂	L ₃	S	S ₁	Bild pic.	Sach.-Nr. comp. no.	Artikel-Nr. part no.
6	27	12	-	-	12	14	1	1326/21	W6Lc3d
8	29	14	-	-	12	17	1	1327/21	W8Lc3d
10	30	15	-	-	14	19	1	1329/21	W10Lc3d
12	32	17	-	-	17	22	1	1330/21	W12Lc3d
15	36	21	-	-	19	27	1	1331/21	W15Lc3d
15	52	28	-	-	19	27	2	2910/21	W15Dc3d
15	52	36	64	45	19	27	3	2911/21	W15D01c3d
15	52	36	73	54	19	27	3	2912/21	W15FMD01c3d
18	40	23,5	-	-	24	32	1	1332/21	W18Lc3d
22	44	27,5	-	-	27	36	1	1333/21	W22Lc3d

Winkel-Stutzen

Equal elbows

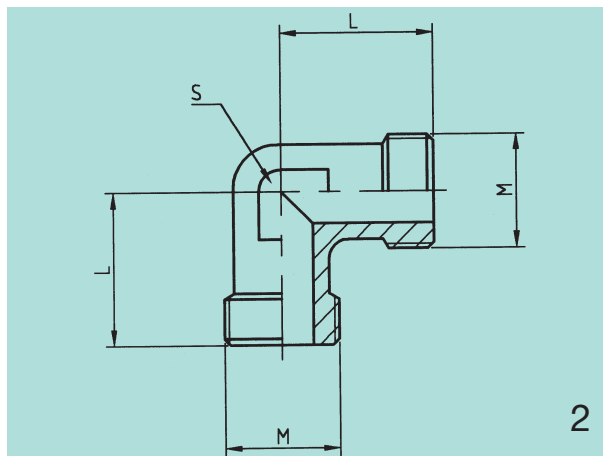
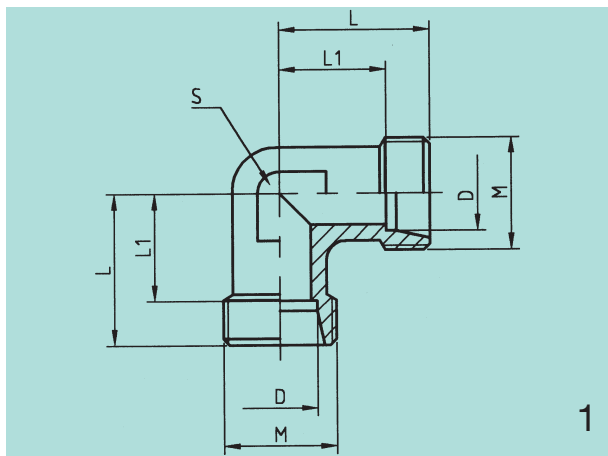

D	L	L ₁	S	M	Bild pic.	Sach.-Nr. comp. no.	Artikel-Nr. part no.
D	L	L ₁	S	M			
6	19	12	12	12x1,5	1	324/21	XW6Lc3d
8	21	14	12	14x1,5	1	325/21	XW8Lc3d
10	22	15	14	16x1,5	1	326/21	XW10Lc3d
12	24	17	17	18x1,5	1	327/21	XW12Lc3d
15	28	21	19	22x1,5	1	328/21	XW15Lc3d
-	28	-	19	22x1,5	2	2279/21	XW15Dc3d
18	31	23,5	24	26x1,5	1	329/21	XW18Lc3d
22	35	27,5	27	30x2	1	330/21	XW22Lc3d

Winkel-Schottverschraubungen

Elbow bulkhead couplings

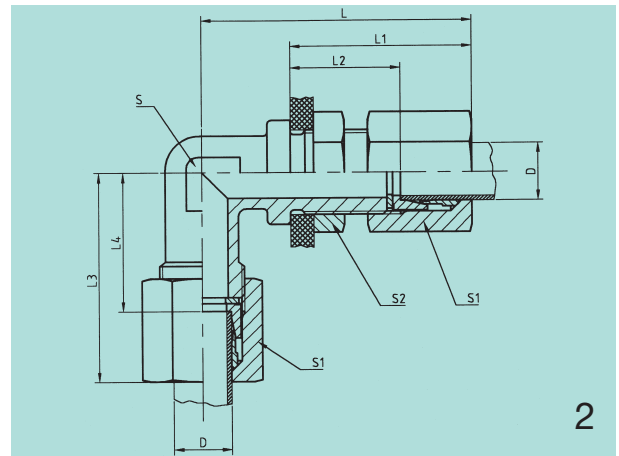
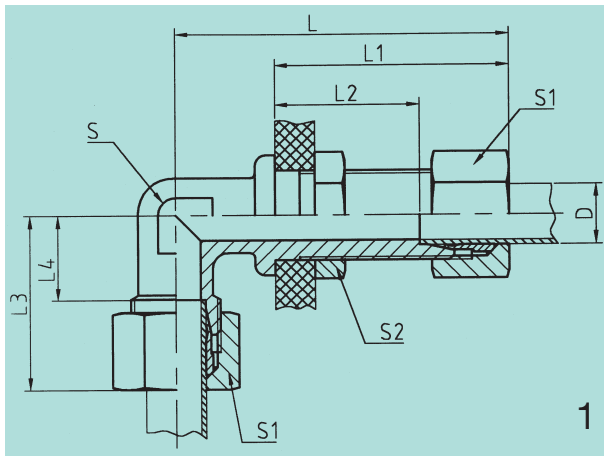

D	L	L ₁	L ₂	L ₃	L ₄	S	S ₁	S ₂	Bild pic.	Sach.-Nr. comp. no.	Artikel-Nr. part no.
6	56	42	27	27	12	12	14	17	1	1418/21	WS6Lc3d
8	59	42	27	29	14	12	17	19	1	1419/21	WS8Lc3d
10	61	43	28	30	15	14	19	22	1	1421/21	WS10Lc3d
12	64	44	29	32	17	17	22	24	1	1423/21	WS12Lc3d
15	69	46	31	36	21	19	27	30	1	1424/21	WS15Lc3d
15	73	53	37	52	36	19	27	27	2	2999/21	WS15DFM01c3d
15	65	45	29	52	36	19	27	27	2	3000/21	WS15D01c3d
18	79	49	32,5	40	23,5	24	32	36	1	1426/21	WS18Lc3d
22	81	51	34,5	44	27,5	27	36	41	1	1427/21	WS22Lc3d

Winkel-Schottstutzen

Elbow bulkhead couplings

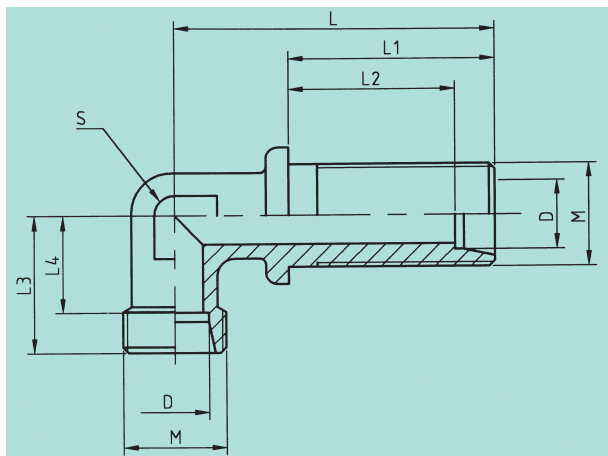

D	L	L ₁	L ₂	L ₃	L ₄	S	M	Sach.-Nr. comp. no.	Artikel-Nr. part no.
6	48	34	27	19	12	12	12x1,5	415/21	XWS6Lc3d
8	51	34	27	21	14	12	14x1,5	416/21	XWS8Lc3d
10	53	35	28	22	15	14	16x1,5	418/21	XWS10Lc3d
12	56	36	29	24	17	17	18x1,5	420/21	XWS12Lc3d
15	61	38	31	28	21	19	22x1,5	422/21	XWS15Lc3d
18	64	42	32,5	31	23,5	24	26x1,5	423/21	XWS18Lc3d
22	72	43	34,5	35	27,5	27	30x2	424/21	XWS22Lc3d

Alle Stutzen auch mit Sechskantmutter lieferbar: Artikelnummer + SM
 Supplied as well with lock nut: part no. + SM

Winkel-Einschraubverschraubungen

Elbow male couplings

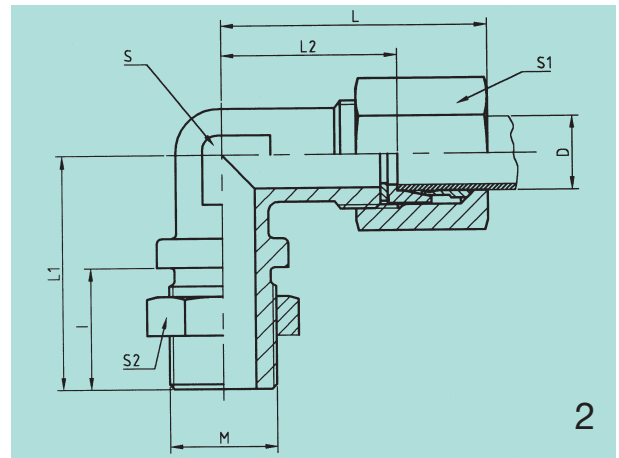
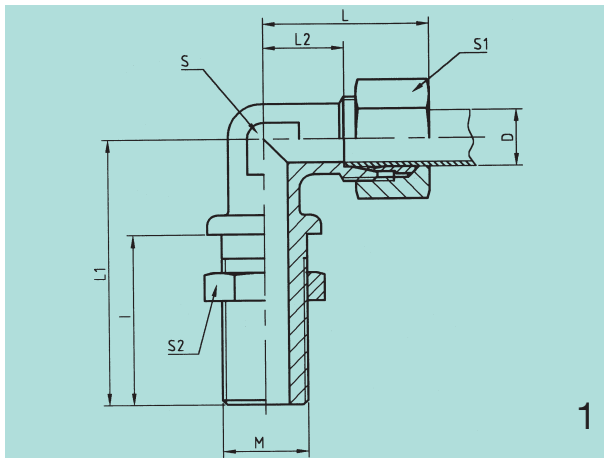

D	I	L	L ₁	L ₂	S	S ₁	S ₂	M	Bild pic.	Sach.-Nr. comp. no.	Artikel-Nr. part no.
6	20	29	38	14	12	14	17	12x1,5	1	2852/21	WE6M12Dc3d
6	20	29	37	14	12	14	22	16x1,5	1	2853/21	WE6M16Dc3d
6	25	32	45	17	17	14	27	22x1,5	1	2854/21	WE6M22Dc3d
8	20	29	38	14	12	17	17	12x1,5	1	2855/21	WE8M12Dc3d
8	20	29	37	14	12	17	19	14x1,5	1	2857/21	WE8M14Dc3d
8	20	29	37	14	12	17	22	16x1,5	1	2858/21	WE8M16Dc3d
8	25	32	45	17	17	17	27	22x1,5	1	2859/21	WE8M22Dc3d
10	20	30	38	14	12	19	17	12x1,5	1	2860/21	WE10M12Dc3d
10	20	30	38	14	12	19	19	14x1,5	1	2861/21	WE10M14Dc3d
10	25	32	45	17	17	19	22	16x1,5	1	2862/21	WE10M16Dc3d
10	25	32	45	17	17	19	27	22x1,5	1	2863/21	WE10M22Dc3d
12	25	32	45	17	17	22	22	16x1,5	1	2864/21	WE12M16D27c3d
12	25	32	45	17	17	22	27	22x1,5	1	2865/21	WE12M22D27c3d
15	25	43	45	26	19	27	27	16x1,5	1	2866/21	WE15M16Dc3d
15	25	52	45	36	19	27	27	16x1,5	2	2867/21	WE15M16D01c3d
15	25	52	45	36	19	27	27	22x1,5	2	2868/21	WE15M22D01c3d
15	25	43	45	26	19	27	27	22x1,5	1	2869/21	WE15M22Dc3d
15	34	52	54	36	19	27	27	22x1,5	2	2870/21	WE15FM22D01c3d
15	25	52	47	39	24	27	32	26x1,5	2	2871/21	WE15M26D01c3d
15	25	43	47	29	24	27	32	26x1,5	1	2872/21	WE15M26Dc3d
16	25	43	45	23	19	27	27	22x1,5	1	2873/21	WE16M22Dc3d
16	25	52	45	36	19	27	27	22x1,5	2	2874/21	WE16M22D27c3d
18	25	55	47	39	24	32	27	22x1,5	2	2875/21	WE18M22D01c3d
18	25	45	47	28,5	24	32	27	22x1,5	1	2876/21	WE18M22Dc3d
18	25	55	47	39	24	32	32	26x1,5	2	2877/21	WE18M26D01c3d
18	25	45	47	28,5	24	32	32	26x1,5	1	2878/21	WE18M26Dc3d

Winkel-Einschraubstutzen

Elbow male couplings

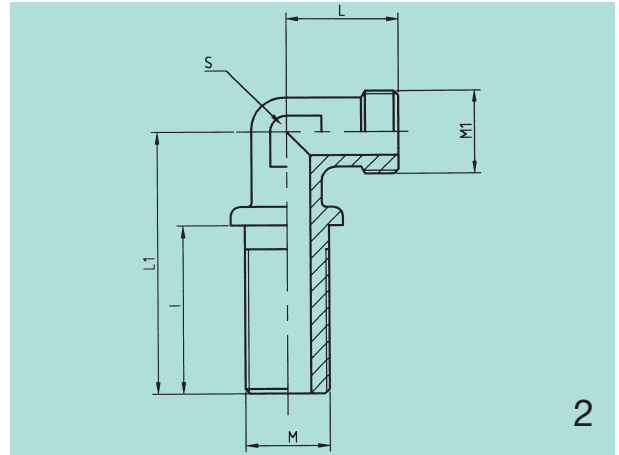
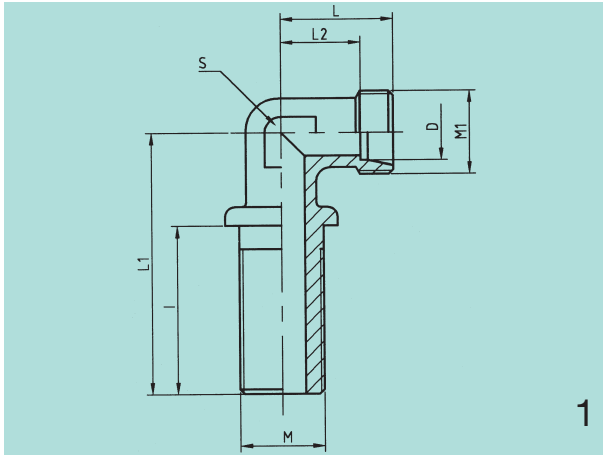

D	I	L	L ₁	L ₂	S	M	M ₁	Bild	Sach.-Nr.	Artikel-Nr.
D	I	L	L ₁	L ₂	S	M	M ₁	pic.	comp. no.	part no.
6	20	21	38	14	12	12x1,5	12x1,5	1	2244/21	XWE6M12Dc3d
6	20	21	37	14	12	16x1,5	12x1,5	1	2245/21	XWE6M16Dc3d
6	25	24	45	17	17	22x1,5	12x1,5	1	2246/21	XWE6M22Dc3d
8	20	21	38	14	12	12x1,5	14x1,5	1	2247/21	XWE8M12Dc3d
8	20	21	37	14	12	14x1,5	14x1,5	1	2249/21	XWE8M14Dc3d
8	20	21	37	14	12	16x1,5	14x1,5	1	2250/21	XWE8M16Dc3d
8	25	24	45	17	17	22x1,5	14x1,5	1	2251/21	XWE8M22Dc3d
10	20	21	37	14	12	12x1,5	16x1,5	1	2252/21	XWE10M12Dc3d
10	20	21	37	14	12	14x1,5	16x1,5	1	2253/21	XWE10M14Dc3d
10	25	24	45	17	17	16x1,5	16x1,5	1	2254/21	XWE10M16Dc3d
10	25	24	45	17	17	22x1,5	16x1,5	1	2255/21	XWE10M22Dc3d
12	25	24	45	17	17	16x1,5	18x1,5	1	2256/21	XWE12M16D15c3d
12	25	24	45	17	17	22x1,5	18x1,5	1	2258/21	XWE12M22D15c3d
15	25	33	45	26	19	16x1,5	22x1,5	1	2260/21	XWE15M16Dc3d
15	25	33	45	26	19	22x1,5	22x1,5	1	2263/21	XWE15M22Dc3d
15	25	36	47	29	24	26x1,5	22x1,5	1	2268/21	XWE15M26Dc3d
-	25	33	45	-	19	16x1,5	22x1,5	2	2261/21	XWE15M16D01c3d
-	25	33	45	-	19	22x1,5	22x1,5	2	2262/21	XWE15M22D01c3d
-	34	33	54	-	19	22x1,5	22x1,5	2	2266/21	XWS15M22D01c3d
-	25	30	42	-	19	22x1,5	22x1,5	2	2265/21	XWE15M22D15c3d
-	25	36	47	-	24	26x1,5	22x1,5	2	2267/21	XWE15M26D01c3d
16	25	30	42	23	19	22x1,5	22x1,5	1	2269/21	XWE16M22Dc3d
18	25	36	47	28,5	24	22x1,5	26x1,5	1	2271/21	XWE18M22Dc3d
18	25	26	47	28,5	24	26x1,5	26x1,5	1	2272/21	XWE18M26Dc3d
-	25	36	47	-	24	22x1,5	26x1,5	2	2270/21	XWE18M22D01c3d
-	25	36	47	-	24	26x1,5	26x1,5	2	2273/21	XWE18M26D01c3d

Alle Stutzen auch mit Sechskantmutter lieferbar: Artikelnummer + SM
 Supplied as well with lock nut: part no. + SM

T-Verschraubungen

Equal tees

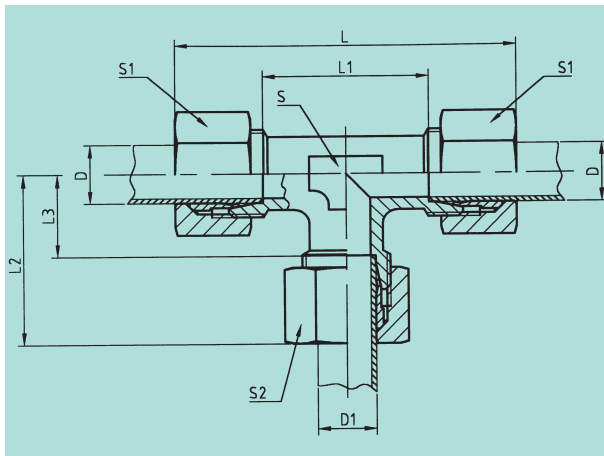

D	D ₁	L	L ₁	L ₂	L ₃	S	S ₁	S ₂	Sach.-Nr. comp. no.	Artikel-Nr. part no.
6	6	54	24	27	12	12	14	14	1352/21	T6Lc3d
6	8	54	28	29	14	12	14	17	2944/21	TR6/8/6Lc3d
8	8	58	28	29	14	12	17	17	1354/21	T8Lc3d
8	6	58	28	29	14	12	17	14	2945/21	TR8/6/8Lc3d
10	10	60	30	30	15	14	19	19	1356/21	T10Lc3d
10	6	60	30	30	15	14	19	14	2946/21	TR10/6/10Lc3d
10	8	60	30	30	15	14	19	17	2951/21	TR10/8/10Lc3d
12	12	64	34	32	17	17	22	22	1357/21	T12Lc3d
12	6	64	34	32	17	17	22	14	2947/21	TR12/6/12Lc3d
12	8	64	34	32	17	17	22	17	2952/21	TR12/8/12Lc3d
12	10	64	34	32	17	17	22	19	2954/21	TR12/10/12Lc3d
12	15	72	42	36	21	19	22	27	2958/21	TR12/15/12Lc3d
15	15	72	42	36	21	19	27	27	1358/21	T15Lc3d
15	6	72	42	36	21	19	27	14	2948/21	TR15/6/15Lc3d
15	8	72	42	36	21	19	27	17	2949/21	TR15/8/15Lc3d
15	10	72	42	36	21	19	27	19	2955/21	TR15/10/15Lc3d
15	12	72	42	36	21	19	27	22	2956/21	TR15/12/15Lc3d
18	18	80	47	40	23,5	24	32	32	1359/21	T18Lc3d
22	22	88	55	44	27,5	27	36	36	1360/21	T22Lc3d

T-Stutzen

Equal tees

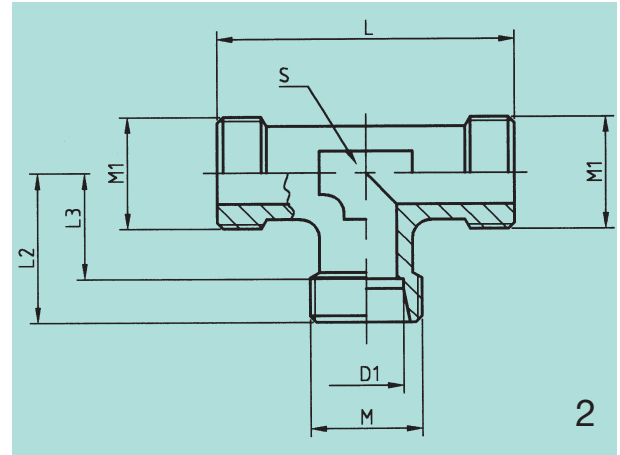
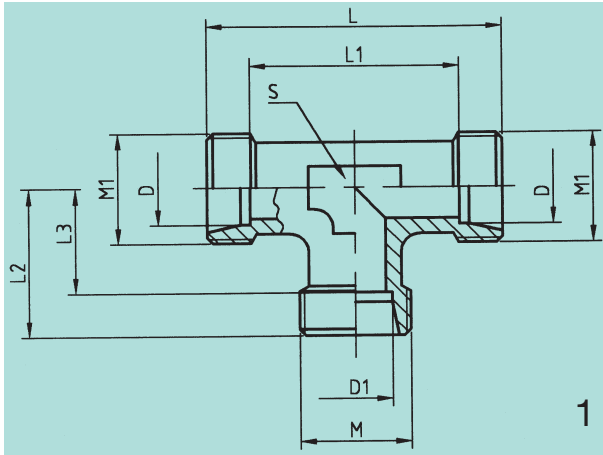

D	D ₁	L	L ₁	L ₂	L ₃	S	M ₁	M	Bild pic.	Sach.-Nr. comp. no.	Artikel-Nr. part no.
6	6	38	24	19	12	12	12x1,5	12x1,5	1	349/21	XT6Lc3d
6	8	42	28	21	14	12	12x1,5	14x1,5	1	2322/21	XTR6/8/6Lc3d
8	8	42	28	21	14	12	14x1,5	14x1,5	1	351/21	XT8Lc3d
8	6	42	28	21	14	12	14x1,5	12x1,5	1	2323/21	XTR8/6/8Lc3d
10	10	44	30	22	15	14	16x1,5	16x1,5	1	353/21	XT10Lc3d
10	6	44	30	22	15	14	16x1,5	12x1,5	1	2324/21	XTR10/6/10Lc3d
10	8	44	30	22	15	14	16x1,5	14x1,5	1	2328/21	XTR10/8/10Lc3d
12	12	48	34	24	17	17	18x1,5	18x1,5	1	354/21	XT12Lc3d
12	6	48	34	24	17	17	18x1,5	12x1,5	1	2325/21	XTR12/6/12Lc3d
12	8	48	34	24	17	17	18x1,5	14x1,5	1	2329/21	XTR12/8/12Lc3d
12	10	48	34	24	17	17	18x1,5	16x1,5	1	2330/21	XTR12/10/12Lc3d
12	15	56	42	28	21	19	18x1,5	22x1,5	1	2335/21	XTR12/15/12Lc3d
15	15	56	42	28	21	19	22x1,5	22x1,5	1	355/21	XT15Lc3d
15	6	56	42	28	21	19	22x1,5	12x1,5	1	2326/21	XTR15/6/15Lc3d
15	8	56	42	28	21	19	22x1,5	14x1,5	1	2327/21	XTR15/8/15Lc3d
15	10	56	42	28	21	19	22x1,5	16x1,5	1	2333/21	XTR15/10/15Lc3d
15	12	56	42	28	21	19	22x1,5	18x1,5	1	2334/21	XTR15/12/15Lc3d
15	6	56	-	28	21	19	22x1,5	12x1,5	2	2337/21	XTR15/6/15Dc3d
15	8	56	-	28	21	19	22x1,5	14x1,5	2	2331/21	XTR15/8/15Dc3d
15	10	56	-	28	21	19	22x1,5	16x1,5	2	2332/21	XTR15/10/15Dc3d
15	12	56	-	28	21	19	22x1,5	18x1,5	2	2600/21	XTR15/12/15Dc3d
18	18	62	47	31	23,5	24	26x1,5	26x1,5	1	356/21	XT18Lc3d
22	22	70	55	35	27,5	27	30x2	30x2	1	357/21	XT22Lc3d

T-Verschraubungen

Tee reduction couplings

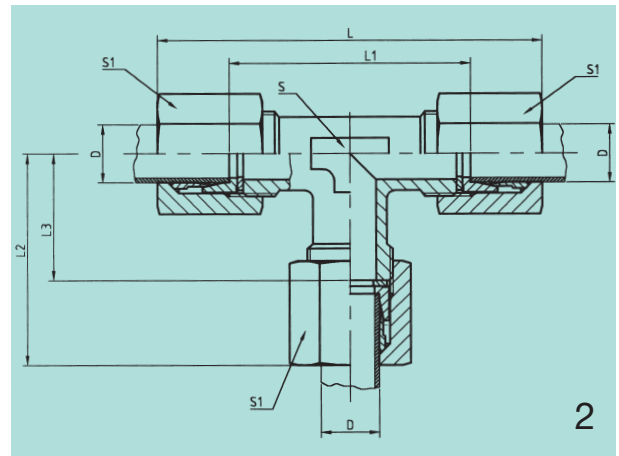
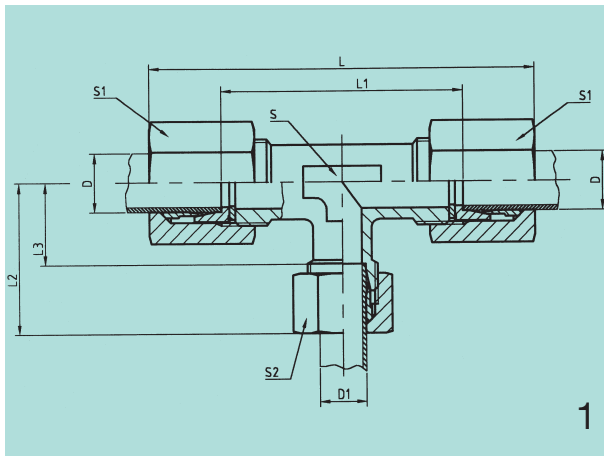

D	D ₁	L	L ₁	L ₂	L ₃	S	S ₁	S ₂	Bild pic.	Sach.-Nr. comp. no.	Artikel-Nr. part no.
15	6	94	62	38	21	19	27	14	1	2950/21	TR15/6/15Dc3d
15	8	94	62	38	21	19	27	17	1	2953/21	TR15/8/15Dc3d
15	10	94	62	38	21	19	27	19	1	2957/21	TR15/10/15Dc3d
15	12	94	62	38	21	19	27	22	1	3142/21	TR15/12/15Dc3d
15	15	94	62	47	31	19	27	27	2	2942/21	T15D02c3d
18	18	108	70	54	35	24	32	32	2	2943/21	T18D02c3d

T-Stützen

Equal tee

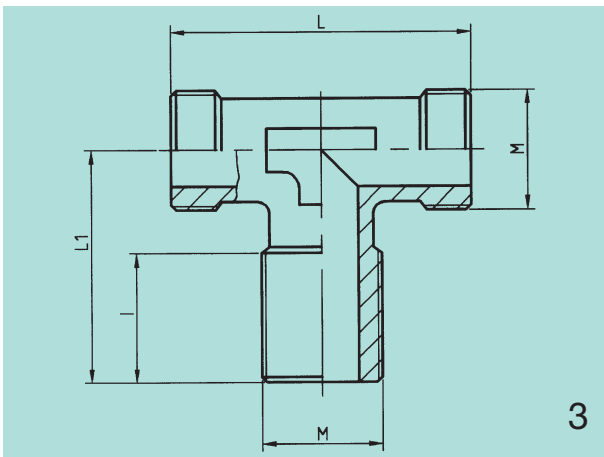
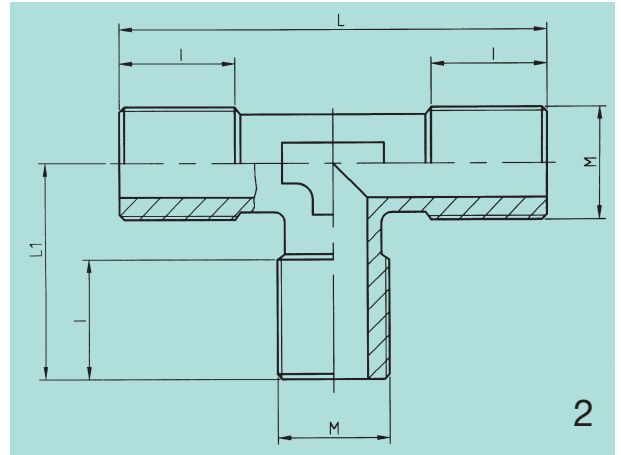
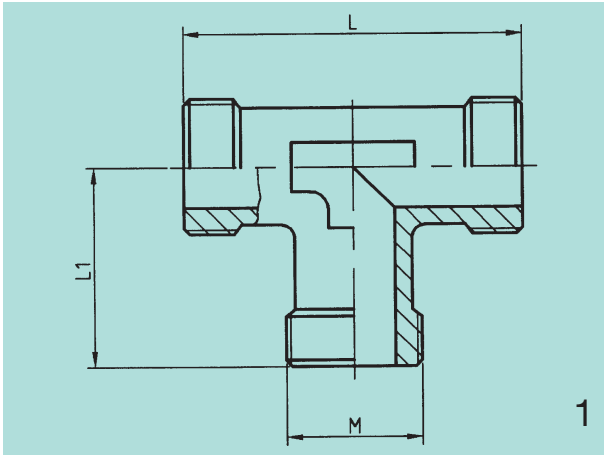

I	L	L ₁	M	Bild pic.	Sach.-Nr. comp. no.	Artikel-Nr. part no.
-	56	28	22x1,5	1	2312/21	XT15D02c3d
-	70	35	26x1,5	1	2313/21	XT18D02c3d
24	84	42	22x1,5	2	2315/21	XTE15M22D02c3d
24	84	42	22x1,5	2	2316/21	XTE16M22D17c3d
34	70	54	22x1,5	3	2319/21	XTS15D02c3d

Alle Stützen auch mit Sechskantmutter lieferbar: Artikelnummer + SM
 Supplied as well with lock nut: part. no + SM

T-Einschraubverschraubungen

Tee male couplings

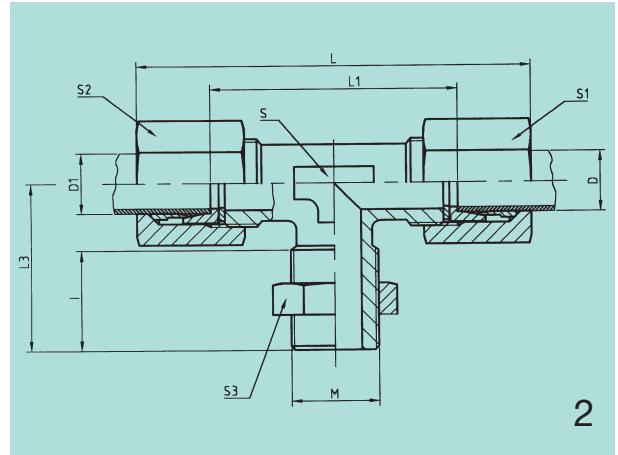
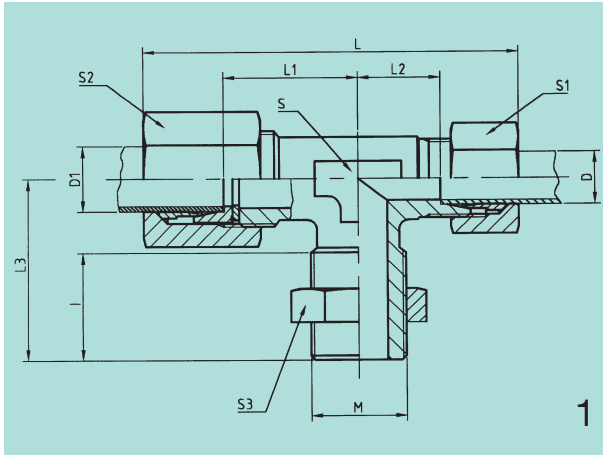

D	D ₁	I	L	L ₁	L ₂	L ₃	S	S ₁	S ₂	S ₃	M	Bild pic.	Sach.-Nr. comp. no	Artikel-Nr. part no.
6	15	25	79	34	17	42	19	27	14	27	22x1,5	1	2914/21	TE15/6M22D02c3d
10	15	25	84	34	19	42	19	27	19	27	22x1,5	1	2916/21	TE15/10M22D02c3d
15	15	34	109	76	-	54	19	27	27	27	22x1,5	2	2936/21	TE15DM22D02c3d ²⁾
15	15	25	122	90	-	42	-	27	27	27	22x1,5	2	2938/21	TE15M22D02c3d
16	16	25	122	90	-	42	-	27	27	27	22x1,5	2	2939/21	TE16M22D27c3d
18	18	34	109	78	-	54	22	32	32	27	22x1,5	2	2937/21	TE18DM22D02c3d ²⁾

²⁾ Ausführung mit Bund

²⁾ Design with collar

Tee male couplings

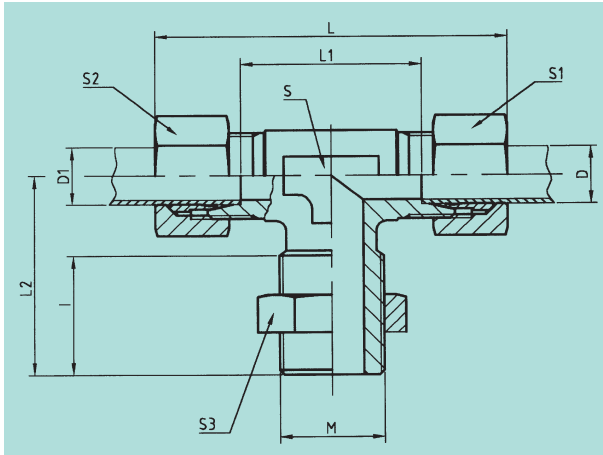

D	D ₁	I	L	L ₁	L ₂	S	S ₁	S ₂	S ₃	M	Sach.-Nr. comp. no.	Artikel-Nr. part no.	
6	6	20	54	24	30	12	14	14	17	12x1,5	2917/21	TE6M12Dc3d	
6	6	25	70	42	42	19	14	14	27	22x1,5	2920/21	TE6M22Dc3d	
8	6	20	58	28	29	12	17	14	17	12x1,5	2922/21	TE8/6M12Dc3d	
8	8	20	58	28	29	12	17	17	17	12x1,5	2921/21	TE8M12Dc3d	
8	8	20	60	30	37	17	17	17	22	16x1,5	2923/21	TE8M16Dc3d	
8	8	25	70	42	45	19	17	17	27	22x1,5	2924/21	TE8M22Dc3d	
10	6	20	62	34	37	17	19	14	22	16x1,5	2928/21	TE10/6M16Dc3d	
10	6	25	70	42	45	19	19	14	27	22x1,5	2929/21	TE10/6M22Dc3d	³⁾
10	10	20	64	34	37	17	19	19	19	14x1,5	2925/21	TE10M14Dc3d	
10	10	20	64	34	37	17	19	19	22	16x1,5	2926/21	TE10M16Dc3d	
10	10	25	72	42	45	19	19	19	27	22x1,5	2927/21	TE10M22Dc3d	³⁾
12	6	20	64	34	37	17	22	14	22	16x1,5	2932/21	TE12/6M16Dc3d	
12	6	25	72	42	45	19	22	14	27	22x1,5	2934/21	TE12/6M22Dc3d	³⁾
12	8	20	64	34	37	19	22	17	22	16x1,5	2933/21	TE12/8M16Dc3d	
12	8	25	72	42	45	17	22	17	27	22x1,5	2935/21	TE12/8M22Dc3d	³⁾
12	12	21	64	34	37	17	22	22	22	16x1,5	2930/21	TE12M16Dc3d	
12	12	25	72	42	45	19	22	22	27	22x1,5	2931/21	TE12M22Dc3d	³⁾
15	6	25	70	40	42	17	27	14	27	22x1,5	2913/21	TE15/6M22Dc3d	
15	10	25	72	42	42	17	27	19	27	22x1,5	2915/21	TE15/10M22Dc3d	

³⁾ Ausführung mit oder ohne Bund nach unserer Wahl

³⁾ Design with or without collar like our choice

T-Einschraubstutzen

Tee male couplings

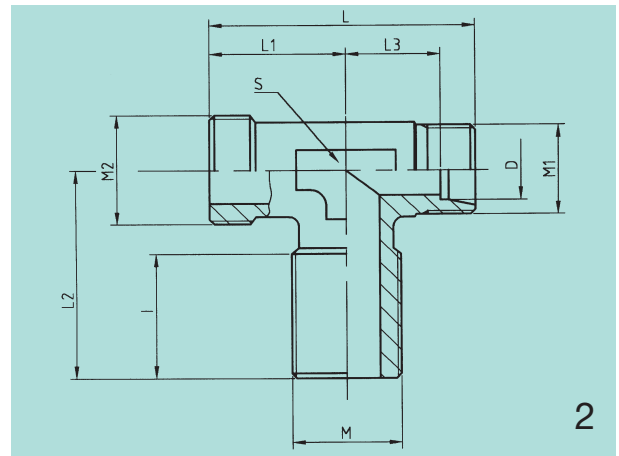
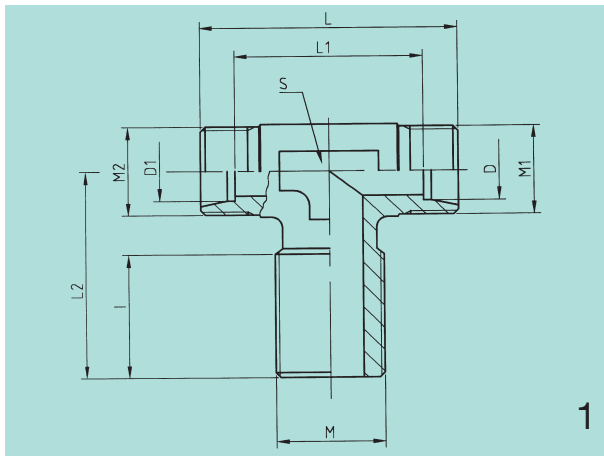

D	D ₁	I	L	L ₁	L ₂	L ₃	S	M	M ₁	M ₂	Bild pic.	Sach.-Nr. comp. no.	Artikel-Nr. part no.
6	6	20	38	24	30	-	14	12x1,5	12x1,5	12x1,5	1	2292/21	XTE6M12Dc3d
6	6	25	56	42	42	-	19	22x1,5	12x1,5	12x1,5	1	2295/21	XTE6M22Dc3d
8	6	20	42	28	29	-	14	12x1,5	12x1,5	14x1,5	1	2297/21	XTE8/6M12Dc3d
8	8	20	42	28	29	-	14	12x1,5	14x1,5	14x1,5	1	2296/21	XTE8M12Dc3d
8	8	20	44	30	37	-	17	16x1,5	14x1,5	14x1,5	1	2298/21	XTE8M16Dc3d
8	8	25	56	42	45	-	19	22x1,5	14x1,5	14x1,5	1	2300/21	XTE8M22Dc3d
10	6	20	48	34	37	-	17	16x1,5	12x1,5	16x1,5	1	2304/21	XTE10/6M16Dc3d
10	6	25	56	42	45	-	19	22x1,5	12x1,5	16x1,5	1	2305/21	XTE10/6M22Dc3d
10	10	20	48	34	37	-	17	14x1,5	16x1,5	16x1,5	1	2301/21	XTE10M14Dc3d
10	10	20	48	34	37	-	17	16x1,5	16x1,5	16x1,5	1	2302/21	XTE10M16Dc3d
10	10	25	56	42	45	-	19	22x1,5	16x1,5	16x1,5	1	2303/21	XTE10M22Dc3d
12	6	20	48	34	37	-	17	16x1,5	12x1,5	18x1,5	1	2308/21	XTE12/6M16Dc3d
12	6	25	56	42	45	-	19	22x1,5	12x1,5	18x1,5	1	2310/21	XTE12/6M22Dc3d
12	8	20	48	34	37	-	17	16x1,5	14x1,5	18x1,5	1	2309/21	XTE12/8M16Dc3d
12	8	25	56	42	45	-	19	22x1,5	14x1,5	18x1,5	1	2311/21	XTE12/8M22Dc3d
12	12	20	48	34	37	-	17	16x1,5	18x1,5	18x1,5	1	2306/21	XTE12M16Dc3d
12	12	25	56	42	45	-	19	22x1,5	18x1,5	18x1,5	1	2307/21	XTE12M22Dc3d
15	6	25	54	40	42	-	19	22x1,5	12x1,5	22x1,5	1	2280/21	XTE15/6M22Dc3d
15	6	25	54	30	42	17	19	22x1,5	12x1,5	22x1,5	2	2281/21	XTE15/6M22D02c3d
15	10	25	56	42	42	-	19	22x1,5	16x1,5	22x1,5	1	2282/21	XTE15/10M22Dc3d
15	10	25	56	30	42	19	19	22x1,5	16x1,5	22x1,5	2	2283/21	XTE15/10M22D02c3d

³⁾ Ausführung mit oder ohne Bund nach unserer Wahl

³⁾ Design with or without collar like our choice

L-Einschraubverschraubungen

Male stud run tee couplings

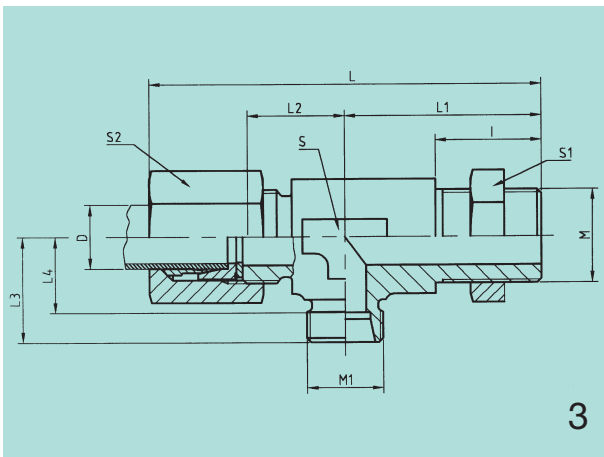
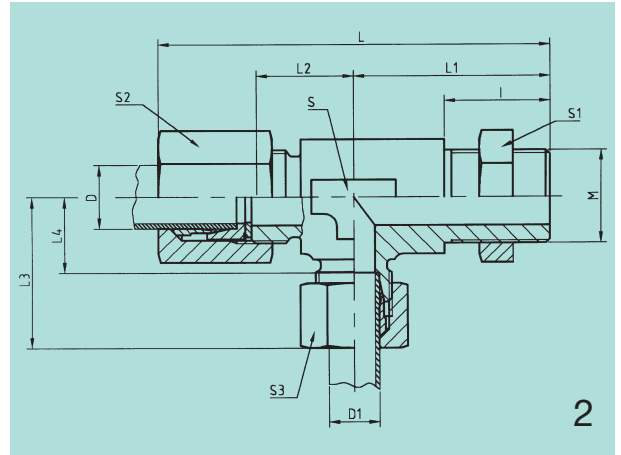
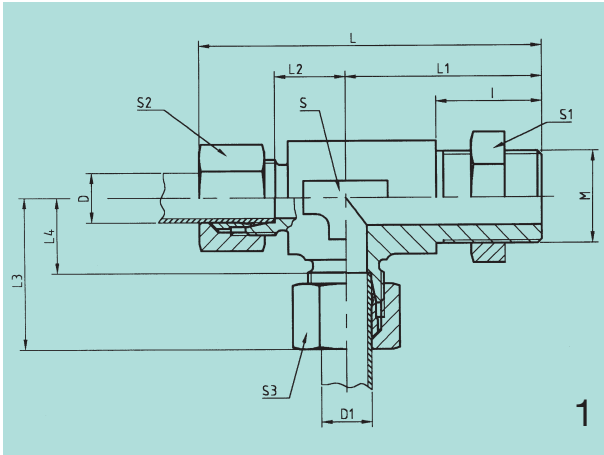

D	D ₁	I	L	L ₁	L ₂	L ₃	L ₄	S	S ₁	S ₂	S ₃	M	M ₁	Bild pic.	Sach.-Nr. comp. no.	Artikel-Nr. part no.
10	6	24	70	38	17	32	17	17	19	22	14	16x1,5	-	1	2970/21	LE10/6M16Dc3d
10	6	25	61	33	13	33	18	27	19	27	14	22x1,5	-	1	2971/21	LE10/6M22Dc3d
12	6	24	70	38	17	32	17	17	22	22	14	16x1,5	-	1	2972/21	LE12/6M16D27c3d
12	8	24	70	38	17	32	17	17	22	22	17	16x1,5	-	1	2974/21	LE12/8M16D27c3d
12	12	24	70	38	17	33	17	17	22	22	22	16x1,5	-	1	2976/21	LE12/12M16Dc3d
15	6	25	72	33	23	33	18	27	27	27	14	22x1,5	-	2	2965/21	LE15/6M22D02c3d
15	6	25	63	33	13	33	18	27	27	27	14	22x1,5	-	1	2966/21	LE15/6M22Dc3d
15	-	25	72	33	23	25	18	27	27	27	-	22x1,5	12x1,5	3	2969/21	LE15M12M22D02c3d
16	6	22	74	34	24	32	17	19	27	27	14	22x1,5	-	2	2977/21	LE16/6M22D27c3d
16	8	22	74	34	24	32	17	19	27	27	17	22x1,5	-	2	2978/21	LE16/8M22D27c3d
18	6	25	75	33	26	33	18	27	32	27	14	22x1,5	-	2	2968/21	LE18/6M22D02c3d

L-Einschraubverschraubungen

Male stud run tee couplings

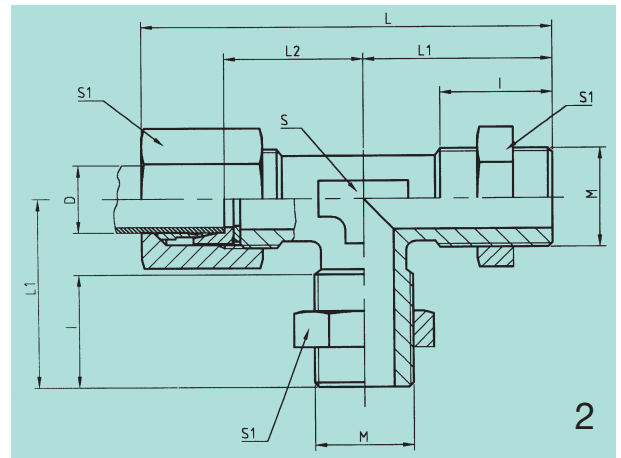
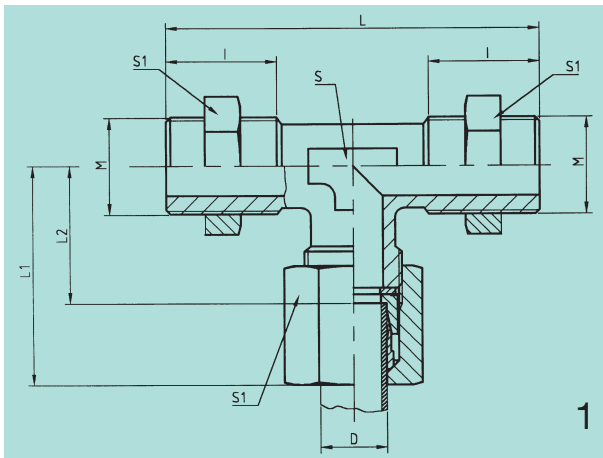

D	I	L	L ₁	L ₂	S	M	Bild pic.	Sach.-Nr. comp. no.	Artikel-Nr. part no.
15	24	84	61	45	27	22x1,5	1	2960/21	LEM22/15/M22/D02c3d
15	24	103	42	45	27	22x1,5	2	2961/21	LE15M22M22D02c3d

L-Einschraubstutzen

Male stud run tee couplings

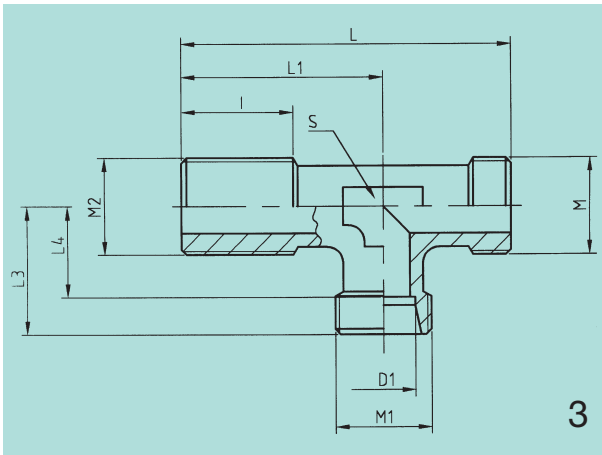
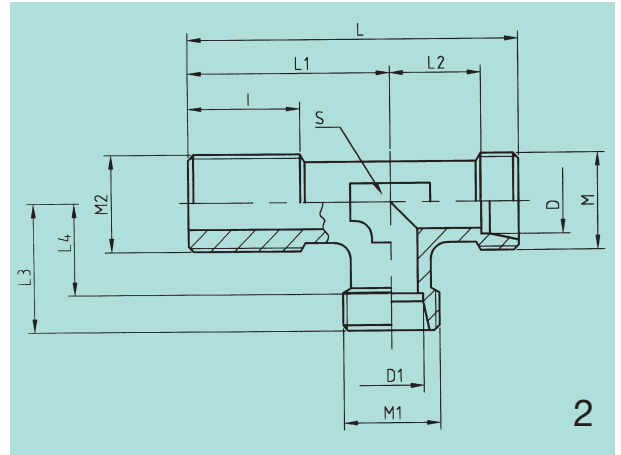
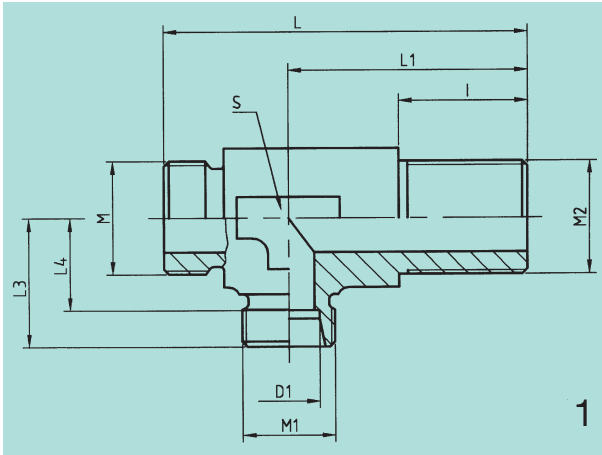

D	D ₁	I	L	L ₁	L ₂	L ₃	L ₄	S	M	M ₁	M ₂	Bild	Sach.-Nr.	Artikel-Nr.
D	D ₁	I	L	L ₁	L ₂	L ₃	L ₄	S	M	M ₁	M ₂	pic.	comp. no.	part no.
10	6	24	62	38	17	24	17	17	16x1,5	12x1,5	16x1,5	2	2345/21	XLE10/6M16Dc3d
10	6	25	53	33	13	24	17	27	16x1,5	12x1,5	22x1,5	2	2346/21	XLE10/6M22Dc3d
12	6	24	62	38	17	24	17	17	18x1,5	12x1,5	16x1,5	2	2347/21	XLE12/6D17c3d
12	8	24	62	38	17	24	17	17	18x1,5	14x1,5	16x1,5	2	2349/21	XLE12/8D17c3d
12	12	24	62	38	17	24	17	17	18x1,5	18x1,5	16x1,5	2	2351/21	XLE12/12M16Dc3d
15	6	25	53	33	13	25	18	27	22x1,5	12x1,5	22x1,5	2	2342/21	XLE15/6M22Dc3d
-	6	25	53	33	13	25	18	27	22x1,5	12x1,5	22x1,5	1	2340/21	XLE15M22D02c3d
-	6	25	55	34	-	24	17	19	22x1,5	12x1,5	22x1,5	3	2353/21	XLE16/6D17c3d
-	8	22	55	34	-	24	17	19	22x1,5	14x1,5	22x1,5	3	2354/21	XLE16/8D17c3d
-	6	25	56	33	-	25	18	27	26x1,5	12x1,5	22x1,5	1	2344/21	XLE18M22D02c3d

Kreuz-Einschraubverschraubungen

Cross male couplings

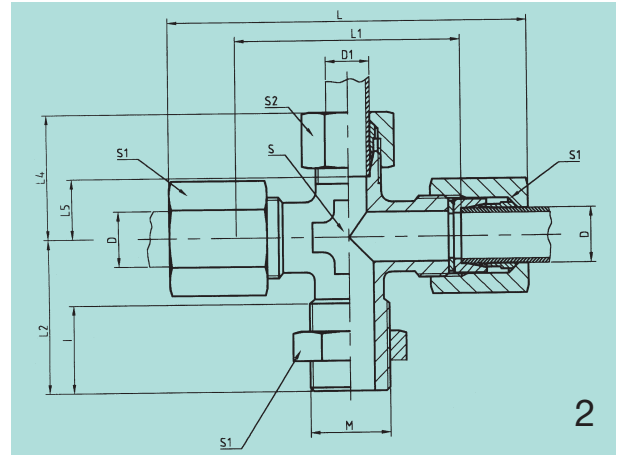
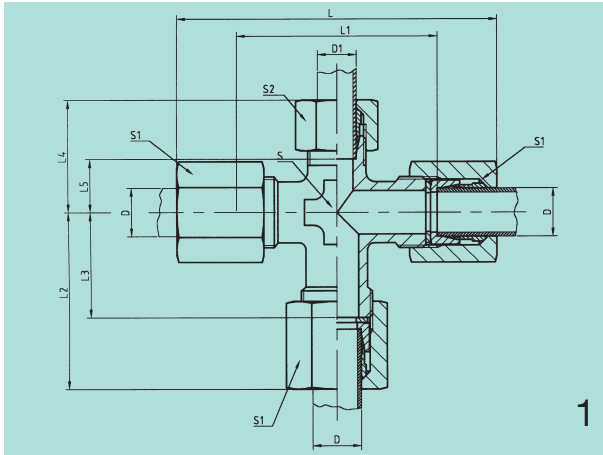

D	D ₁	I	L	L ₁	L ₂	L ₃	L ₄	L ₅	S	S ₁	M	Bild pic.	Sach.-Nr. comp. no.	Artikel-Nr. part no.	
15	6	-	109	76	61	45	32	17	27	14	-	1	2979/21	K15/6D03c3d	1)
15	6	24	109	76	42	-	32	17	27	14	22x1,5	2	2980/21	KE15/6/15D03c3d	1)
16	6	24	96	62	42	-	32	17	27	14	22x1,5	2	2981/21	KE16/6/16M22D27c3d	1)
16	8	24	96	62	42	-	32	17	27	17	22x1,5	2	2982/21	KE16/8/16M22D27c3d	1)

¹⁾ Nur auf Anfrage

¹⁾ Supplied on request

Kreuzstutzen

Cross male couplings

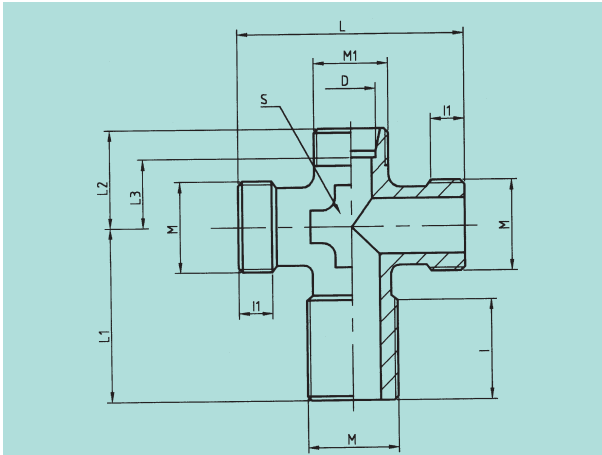

D	I	I ₁	L	L ₁	L ₂	L ₃	S	M	M ₁	Sach.-Nr. comp. no.	Artikel-Nr. part no.	
6	27	20	70	42	24	17	–	22x1,5	12x1,5	2356/21	XK15D03c3d	¹⁾
6	25	9	56	42	24	17	19	22x1,5	12x1,5	2359/21	XK16/6D19c3d	¹⁾
8	25	9	56	42	24	17	19	22x1,5	14x1,5	2360/21	XK16/8D19c3d	¹⁾

¹⁾ Nur auf Anfrage

¹⁾ Supplied on request

Kreuz-Verschraubungen

Cross couplings

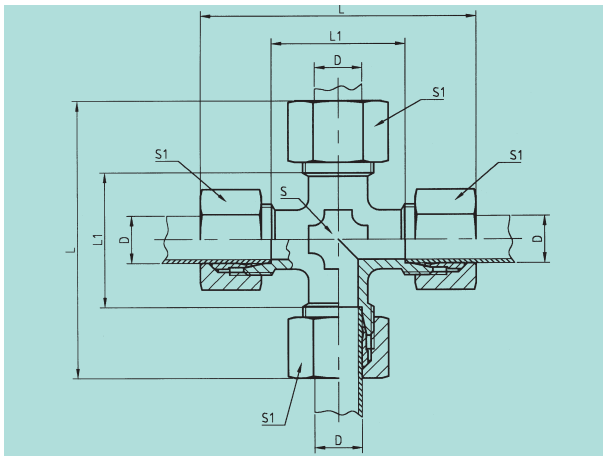

D	L	L ₁	S	S ₁	Sach.-Nr. comp. no.	Artikel-Nr. part no.
6	54	24	12	14	1378/21	K6Lc3d
8	58	28	12	17	1379/21	K8Lc3d
10	60	30	14	19	1380/21	K10Lc3d
12	64	34	17	22	1381/21	K12Lc3d
15	72	42	19	27	1382/21	K15Lc3d
18	80	47	24	32	1383/21	K18Lc3d
22	88	55	27	36	1384/21	K22Lc3d

Kreuzstutzen

Cross connectors

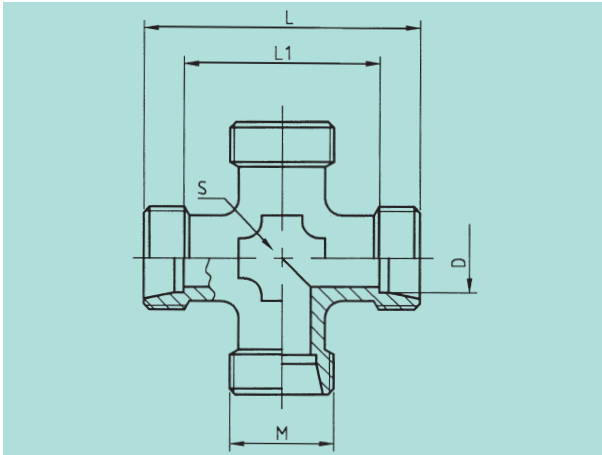

D	L	L ₁	S	M	Sach.-Nr. comp. no.	Artikel-Nr. part no.
D	L	L ₁	S	M		
6	38	24	12	12x1,5	375/21	XK6Lc3d
8	42	28	12	14x1,5	376/21	XK8Lc3d
10	44	30	14	16x1,5	377/21	XK10Lc3d
12	48	34	17	18x1,5	378/21	XK12Lc3d
15	56	42	19	22x1,5	379/21	XK15Lc3d
18	62	47	24	26x1,5	380/21	XK18Lc3d
22	70	55	27	30x2	381/21	XK22Lc3d

Gerade Schottverschraubungen

Bulkhead couplings

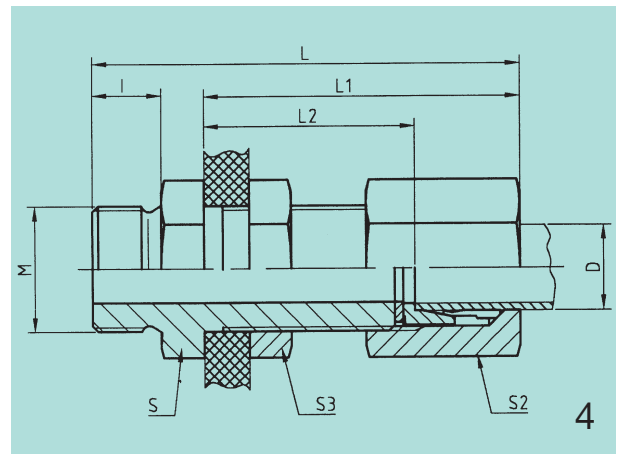
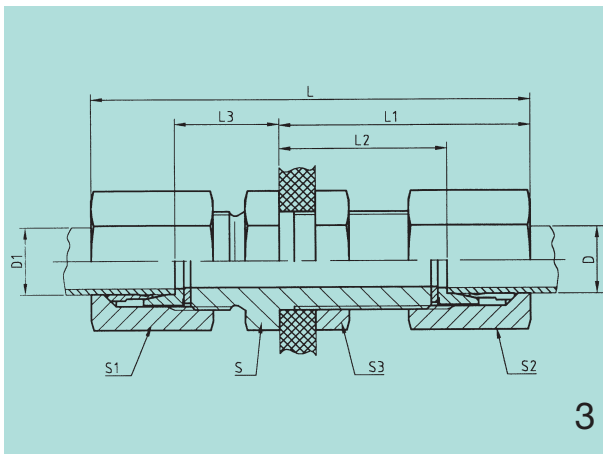
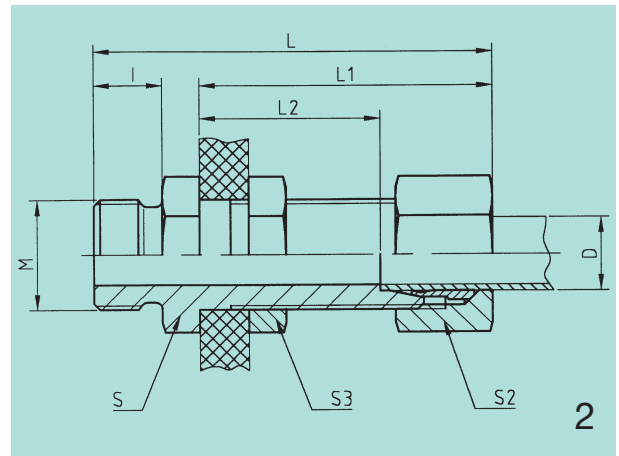
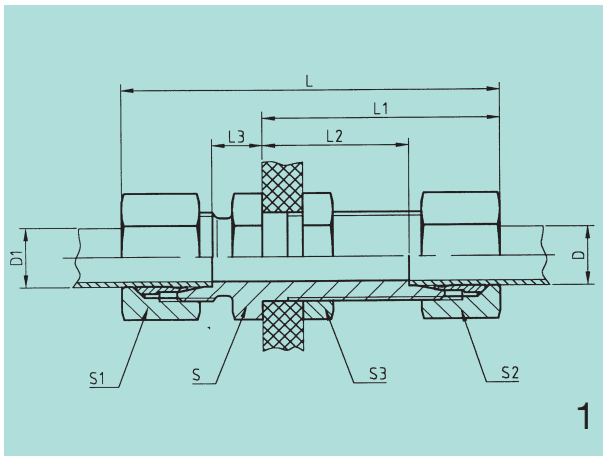

D	D ₁	I	L	L ₁	L ₂	L ₃	S	S ₁	S ₂	S ₃	M	Bild pic.	Sach.-Nr. comp. no.	Artikel-Nr. part no.
D	D ₁	I	L	L ₁	L ₂	L ₃	S	S ₁	S ₂	S ₃	M			
6	6	-	64	42	27	7	17	14	14	17	-	1	1398/21	GS6Lc3d
8	8	-	65	42	27	8	19	17	17	19	-	1	1399/21	GS8Lc3d
10	10	-	68	43	28	10	22	19	19	22	-	1	1400/21	GS10Lc3d
12	12	-	69	44	29	10	24	22	22	24	-	1	1401/21	GS12Lc3d
10	-	12	62	42	27	-	22	-	19	22	16x1,5	2	2983/21	GS10M16Dc3d
10	-	12	62	42	27	-	27	-	19	22	22x1,5	2	2985/21	GS10M22Dc3d
12	-	12	62	42	27	-	22	-	22	24	16x1,5	2	2987/21	GS12M16D27c3d
12	-	12	62	42	27	-	27	-	22	24	22x1,5	2	2988/21	GS12M22D27c3d
15	15	-	73	46	31	12	27	27	27	30	-	1	1402/21	GS15Lc3d
15	15	-	92	53	37	23	27	27	27	27	-	3	2989/21	GS15D99c3d
15	-	12	73	53	37	-	27	-	27	27	16x1,5	4	2991/21	GS15M16D99c3d
15	-	12	73	53	37	-	27	-	27	27	18x1,5	4	2992/21	GS15M18D99c3d
15	-	12	73	53	37	-	27	-	27	27	22x1,5	4	2993/21	GS15M22D99c3d
16	16	-	92	53	37	23	27	27	27	27	-	3	2997/21	GS16D13c3d
16	-	12	73	53	37	-	27	-	27	27	22x1,5	4	2998/21	GS16M22D27c3d
18	18	-	79	49	32,5	13,5	32	32	32	36	-	1	1403/21	GS18Lc3d
22	22	-	84	51	34,5	16,5	36	36	36	41	-	1	1404/21	GS22Lc3d

Gerade Schottstutzen

Bulkhead couplings

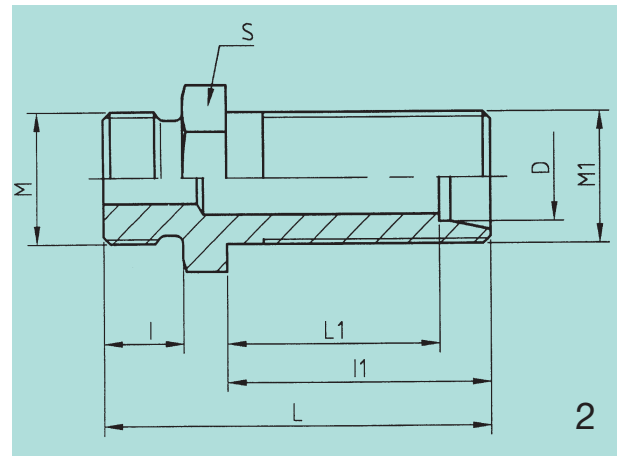
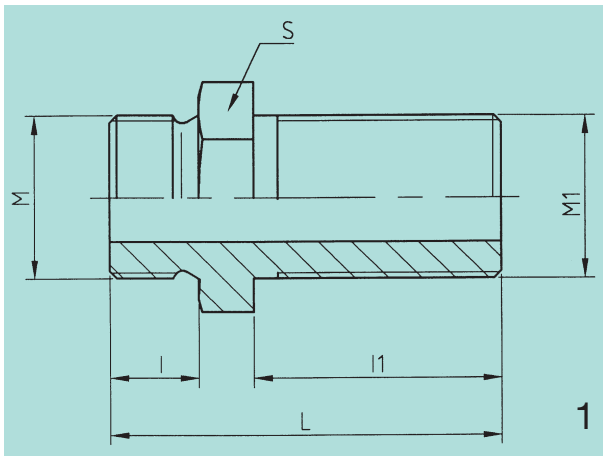

D	I	I ₁	L	L ₁	S	M	M ₁	Bild	Sach.-Nr.	Artikel-Nr.
D	I	I ₁	L	L ₁	S	M	M ₁	pic.	comp. no.	part no.
10	12	34	54	27	22	16x1,5	16x1,5	2	2370/21	XGS10M16Dc3d
10	12	34	54	27	27	22x1,5	16x1,5	2	2371/21	XGS10M22Dc3d
12	12	34	54	27	22	16x1,5	18x1,5	2	2368/21	XGS12M16D13c3d
12	12	34	54	27	27	22x1,5	18x1,5	2	2369/21	XGS12M22D13c3d
-	12	34	54	-	27	16x1,5	22x1,5	1	2361/21	XGS15M16D99c3d
-	12	34	54	-	27	18x1,5	22x1,5	1	2362/21	XGS15M18D99c3d
-	12	34	54	-	27	22x1,5	22x1,5	1	2364/21	XGS15M22D99c3d
-	12	34	54	-	27	22x1,5	22x1,5	1	2367/21	XGS16M22D13c3d
-	12	34	54	-	32	22x1,5	26x1,5	1	2366/21	XGS18M22D99c3d

Alle Stutzen auch mit Sechskantmutter lieferbar: Artikelnummer + SM
 Supplied as well with lock nuts: part. no + SM

Gerade Schottstutzen

Bulkhead connectors

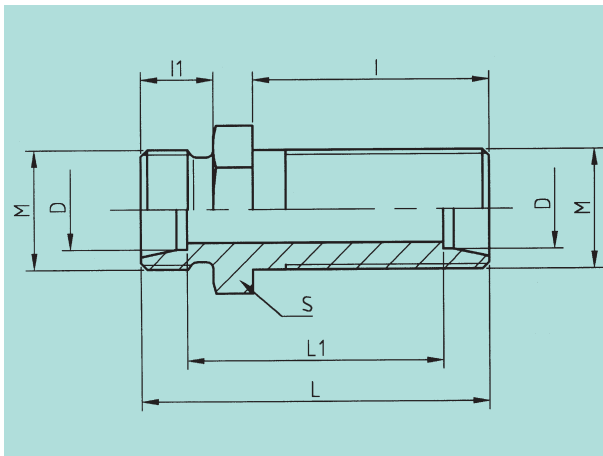

D	I	I ₁	L	L ₁	S	M	Sach.-Nr. comp. no.	Artikel-Nr. part no.
D	I	I ₁	L	L ₁	S	M		
6	34	10	48	34	17	12x1,5	395/21	XGS6Lc3d
8	34	10	49	35	19	14x1,5	396/21	XGS8Lc3d
10	35	11	52	38	22	16x1,5	397/21	XGS10Lc3d
12	36	11	53	39	24	18x1,5	398/21	XGS12Lc3d
15	38	12	57	43	27	22x1,5	399/21	XGS15Lc3d
18	40	12	61	46	32	26x1,5	400/21	XGS18Lc3d
22	42	14	66	51	36	30,2	401/21	XGS22Lc3d

Alle Stutzen auch mit Sechskantmutter lieferbar: Artikelnummer + SM
 Supplied as well with lock nuts: part. no + SM

T-Verschraubungen mit Schlauchanschluss

Tee-couplings with hose coupling

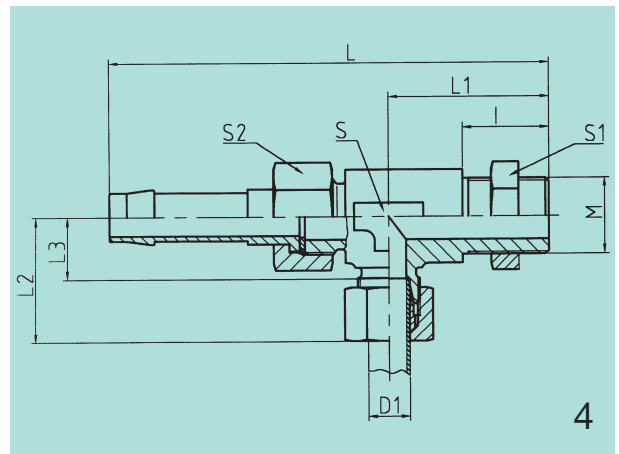
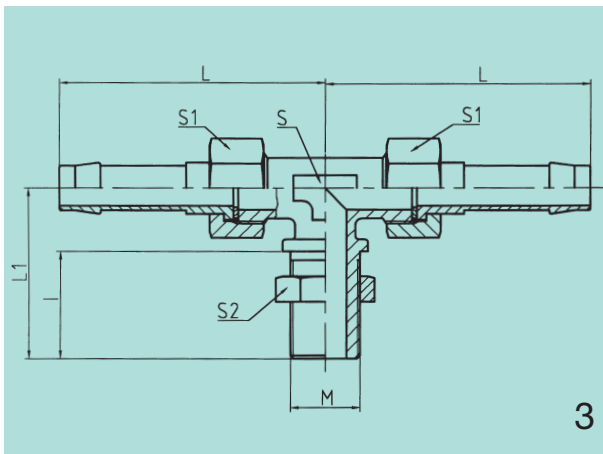
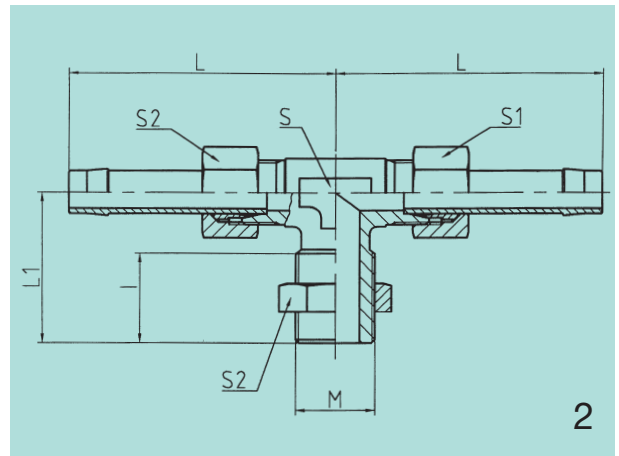
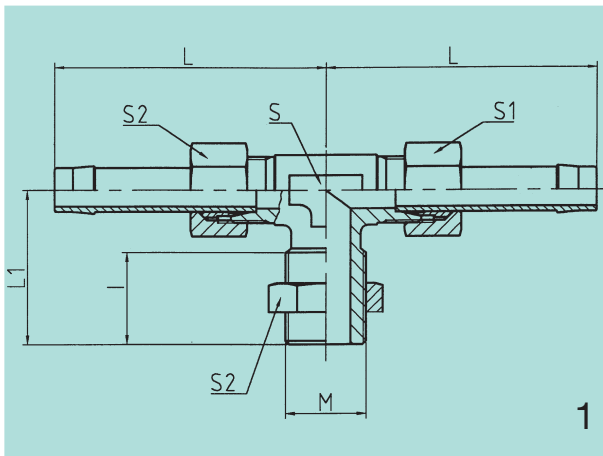

D	D _i	Schlauch Innen ø	I	L	L ₁	L ₂	L ₃	S	S ₁	S ₂	M	Bild pic.	Sach.-Nr. comp. no.	Artikel-Nr. part no.
D	D _i	hose internal ø	I	L	L ₁	L ₂	L ₃	S	S ₁	S ₂	M			
15	-	11	-	91	74	54	37	19	27	27	-	1	3131/21	TSLV11/DM15/11D02c3d
15	-	13	-	91	74	54	37	19	27	27	-	1	3096/21	TSLV13/DM15/13D02c3d
-	-	11	21	74	38	-	-	17	22	22	16x1,5	2	3127/21	TSLV11/M16/11Dc3d
-	-	11	25	80	45	-	-	17	22	27	22x1,5	2	3128/21	TSLV11/M22/11Dc3d
-	-	11	34	91	54	-	-	19	27	27	22x1,5	3	3025/21	TSLV11/DM22/11D02c3d
-	-	13	34	91	54	-	-	19	27	27	22x1,5	3	3024/21	TSLV13/DM22/13D02c3d
-	6	11	25	109	33	33	18	27	27	27	22x1,5	4	3129/21	TSLV11/6M22D02c3d
-	6	13	25	109	33	33	18	27	27	27	22x1,5	4	3130/21	TSLV13/6M22D02c3d

T-Verschraubungen mit Schlauchanschluss

Tee-couplings with hose coupling

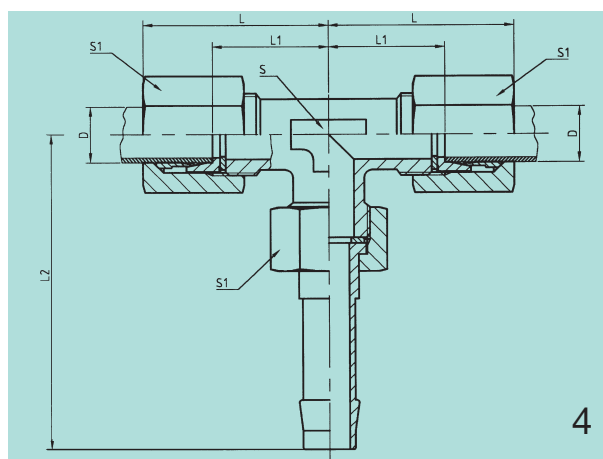
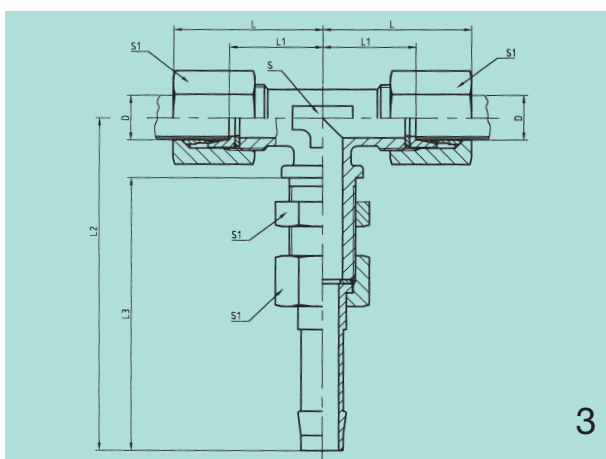
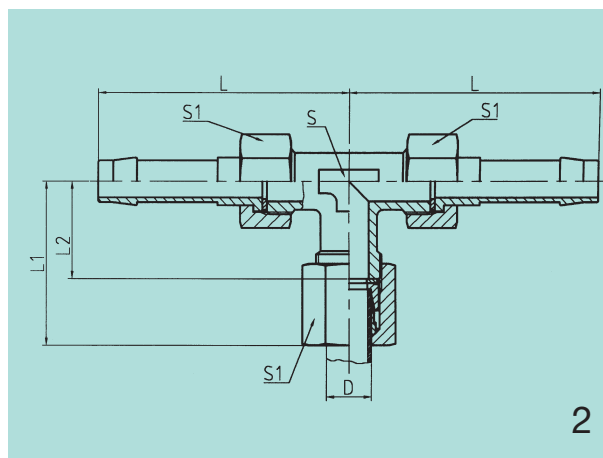
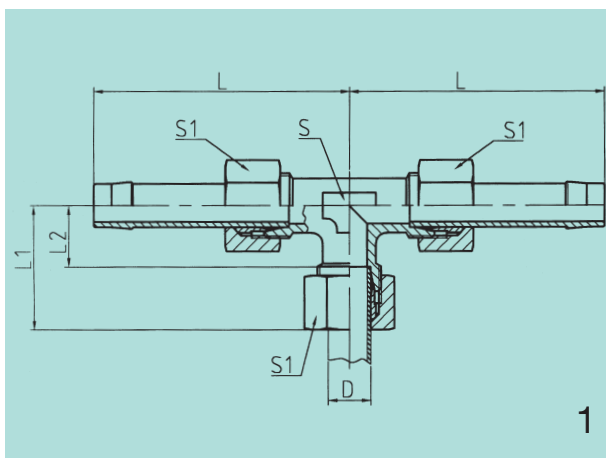

D	Schlauch Innen \varnothing	L	L ₁	L ₂	L ₃	S	S ₁	Bild	Sach.-Nr.	Artikel-Nr.
D	hose internal \varnothing	L	L ₁	L ₂	L ₃	S	S ₁	pic.	comp. no.	part no.
12	11	72	32	17	-	17	22	1	3018/21	TSLV11/12/11Dc3d
15	13	84	47	31	-	19	27	2	3019/21	TSLV13/15/13D02c3d
15	13	54	38	110	90	19	27	3	3020/21	TSLV15D02c3d
15	13	47	31	84	-	19	27	4	3126/21	TSLV15/13/15Dc3d

Elbow couplings with hose coupling

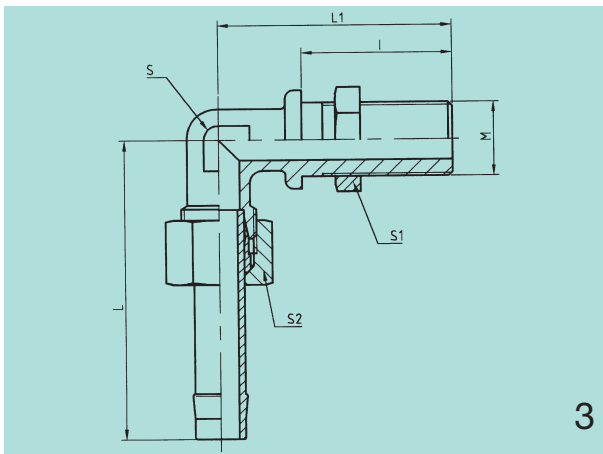
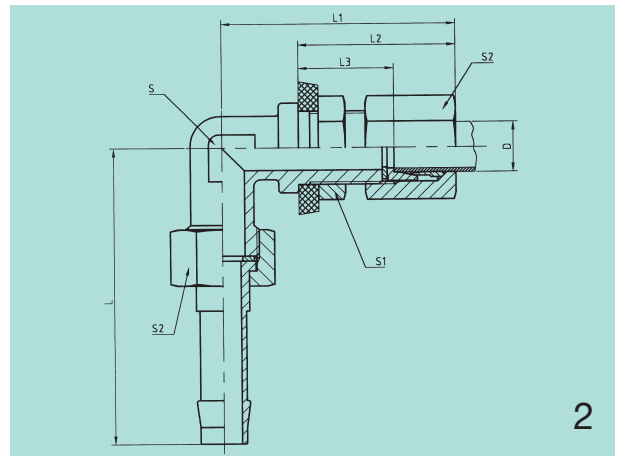
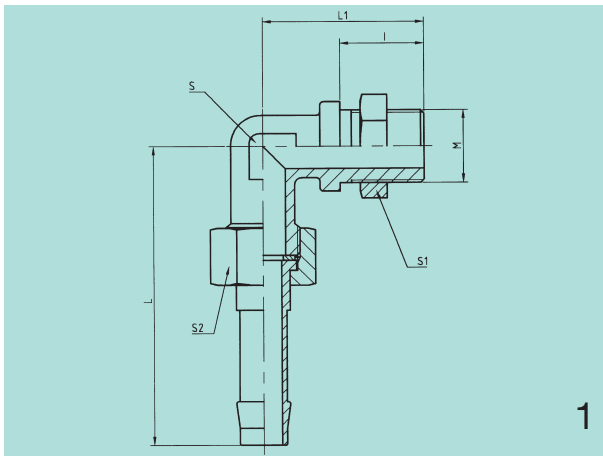

D	I	Schlauch Innen ø	L	L ₁	L ₂	L ₃	S	S ₁	S ₂	M	Bild pic.	Sach.-Nr. comp. no.	Artikel-Nr. part no.
D	I	hose internal ø	L	L ₁	L ₂	L ₃	S	S ₁	S ₂	M			
-	25	11	72	42	-	-	17	22	22	16x1,5	3	3013/21	WSLV11M16Dc3d
-	25	13	90	45	-	-	19	22	27	16x1,5	1	3014/21	WSLV13M16Dc3d
-	25	13	90	45	-	-	19	27	27	22x1,5	1	3015/21	WSLV13M22Dc3d
-	34	13	90	54	-	-	19	27	27	22x1,5	1	3016/21	WSLV13FM22Dc3d
15	-	13	90	65	29	28	19	27	27	-	2	3017/21	WSLV15D01c3d

³⁾ Ausführung mit oder ohne Bund nach unserer Wahl

³⁾ Design with or without collar like our choice

Gerade Schlauchverschraubungen

Straight couplings with hose coupling

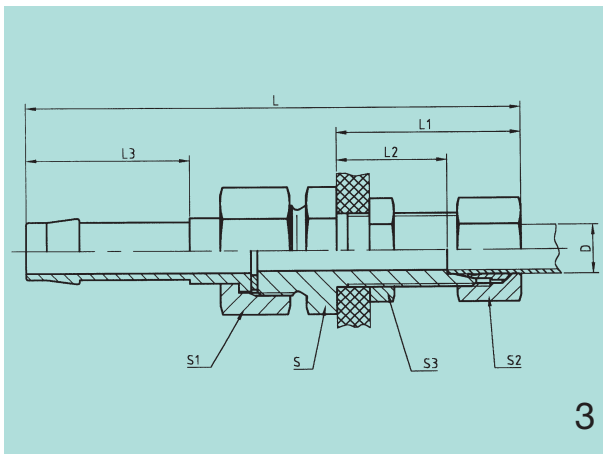
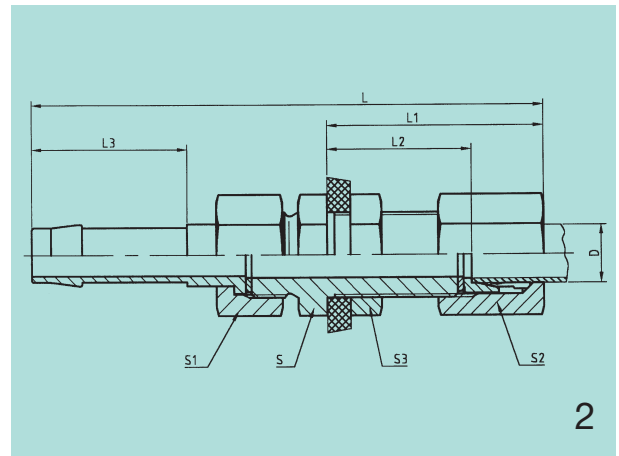
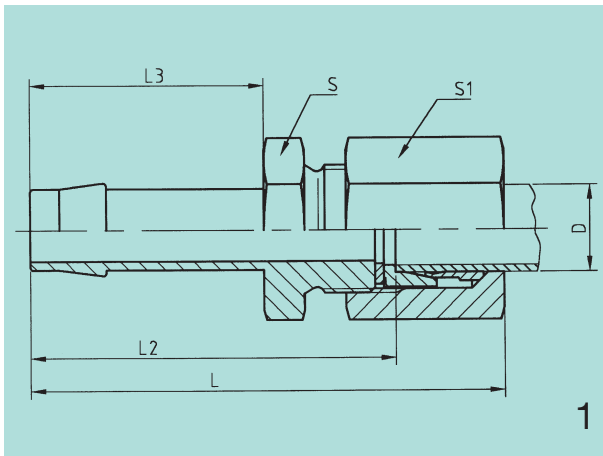

D	S**	L	L ₁	L ₂	L ₃	S	S ₂	S ₃	S ₄	Bild	Sach.-Nr.	Artikel-Nr.
D	S**	L	L ₁	L ₂	L ₃	S	S ₂	S ₃	S ₄	pic.	comp. no.	part no.
15	11	79	-	61,5	40	27	27	-	-	1	3005/21	GSLV-B1511D00c3d
15	13	79	-	62,5	40	27	27	-	-	1	3006/21	GSLV-B15D00c3d
18	13	79	-	62,5	40	32	32	-	-	1	3007/21	GSLV-B18D00c3d
12	11	118	42	27	40	27	27	22	24	3	3008/21	GSLV-C1211D13c3d
12	13	118	42	27	40	27	27	22	24	3	3009/21	GSLV-C1213D13c3d
15	11	129	53	37	40	27	27	27	27	2	3010/21	GSLV-A1511D00c3d
15	13	129	53	37	40	27	27	27	27	2	3011/21	GSLV-A15D00c3d
18	13	129	53	37	40	32	27	32	32	2	3012/21	GSLV-A18D00c3d

S** für Schlauch Innendurchmesser
S** for hose internal diameter

Schlauchstutzen mit Gewinde

Hose nozzles with thread

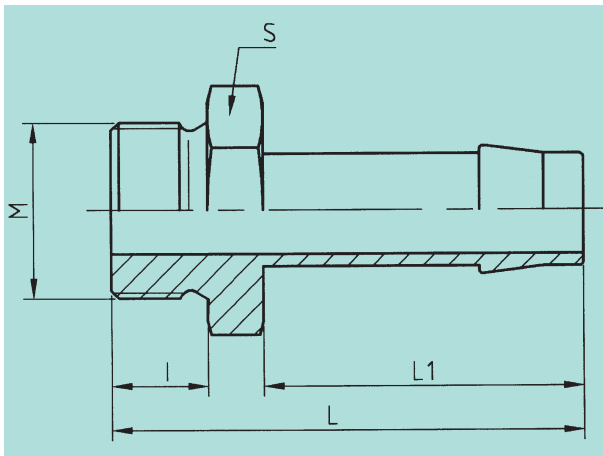

Schlauch Innen \varnothing hose internal \varnothing	I	L	L ₁	S	M	Sach.-Nr. comp. no.	Artikel-Nr. part no.
11	12	58	40	22	16x1,5	2409/21	SL11M16D04c3d
11	12	59	40	27	22x1,5	2410/21	SL11M22D04c3d
13	12	58	40	22	16x1,5	2411/21	SL13M16D04c3d
13	12	59	40	27	22x1,5	2412/21	SL13M22D04c3d
13	12	59	40	32	26x1,5	2413/21	SL13M26D04c3d

Schlauchstutzen

Hose nozzles

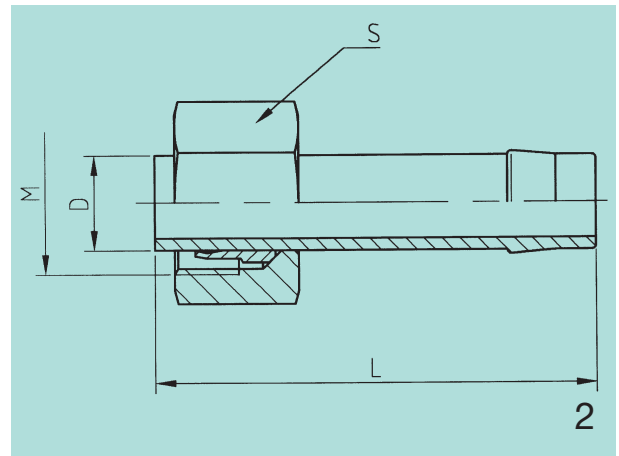
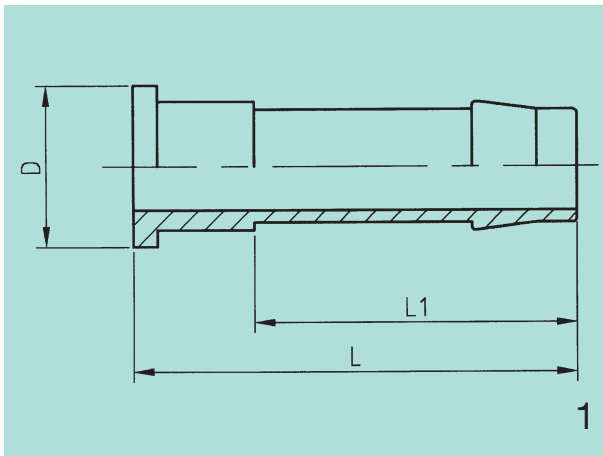

Schlauch Innen ø hose internal ø	D	L	L ₁	S	M	Bild pic.	Sach.-Nr. comp. no.	Artikel-Nr. part no.
11	20	55	40	-	-	1	2414/21	SL11D04c3d
13	20	55	40	-	-	1	2415/21	SL13D04c3d
9	10	-	-	19	16x1,5	2	3028/21	SL9/10c3d
13	10	-	-	19	16x1,5	2	3030/21	SL13/10c3d
11	12	55	-	22	18x1,5	2	3029/21	SL11/12c3d
13	12	55	-	22	18x1,5	2	3031/21	SL13/12c3d
11	15	60	-	27	22x1,5	2	9822/21	SL11/15c3d
13	15	60	-	27	22x1,5	2	9287/21	SL13/15c3d

Reduzierstutzen

Reduction couplings

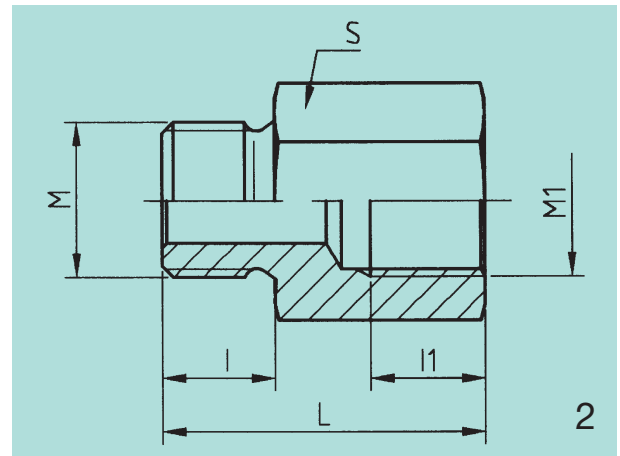
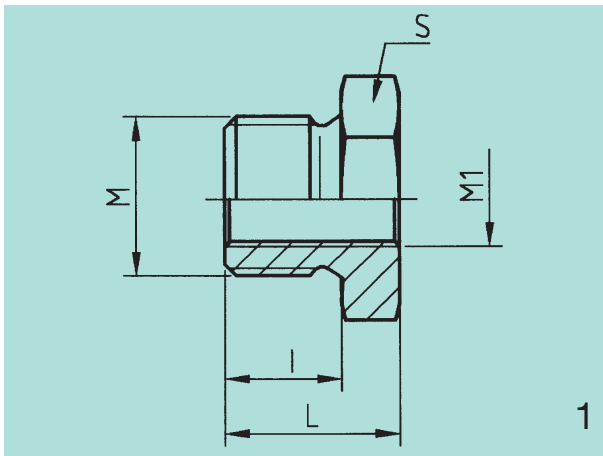

M	M ₁	l	l ₁	L	S	Bild pic.	Sach.-Nr. comp. no.	Artikel-Nr. part no.
M	M ₁	l	l ₁	L	S			
16x1,5	10x1	12	-	18	22	1	2390/21	RSM16M10Dc3d
16x1,5	22x1,5	12	14	35	27	2	2402/21	RSM16M22Dc3d
16x1,5	G1/8A	12	-	18	22	1	2391/21	RSM16R1/8 Dc3d
16x1,5	G1/2A	12	14	35	27	2	2406/21	RSM16R1/2 Dc3d
18x1,5	10x1	12	-	19	24	1	2392/21	RSM18M10Dc3d
18x1,5	12x1,5	12	-	19	24	1	2393/21	RSM18M12Dc3d
18x1,5	22x1,5	12	14	35	27	2	2403/21	RSM18M22Dc3d
22x1,5	10x1	12	-	19	27	1	2590/21	RSM22M10Dc3d
22x1,5	12x1,5	12	-	19	27	1	2394/21	RSM22M12Dc3d
22x1,5	14x1,5	12	-	19	27	1	2395/21	RSM22M14Dc3d
22x1,5	16x1,5	12	-	19	27	1	2396/21	RSM22M16Dc3d
22x1,5	18x1,5	12	14	35	27	2	2397/21	RSM22M18Dc3d
22x1,5	22x1,5	12	14	35	27	2	2404/21	RSM22M22Dc3d
22x1,5	G1/8A	12	-	19	27	1	2398/21	RSM22R1/8 Dc3d
22x1,5	G1/4A	12	-	19	27	1	2399/21	RSM22R1/4Dc3d
22x1,5	G3/8A	12	-	19	27	1	2400/21	RSM22R3/8 Dc3d
22x1,5	G1/2A	12	14	35	27	2	2405/21	RSM22R1/2 Dc3d
26x1,5	18x1,5	12	-	19	32	1	2401/21	RSM26M18Dc3d
26x1,5	22x1,5	12	14	35	32	2	2407/21	RSM26M22Dc3d

Muffen

Screw sleeves

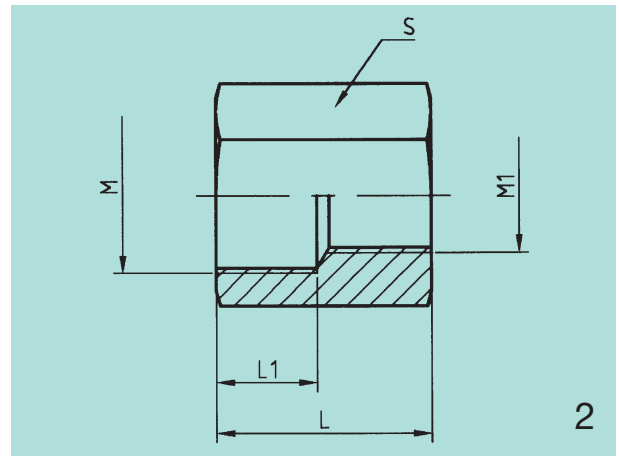
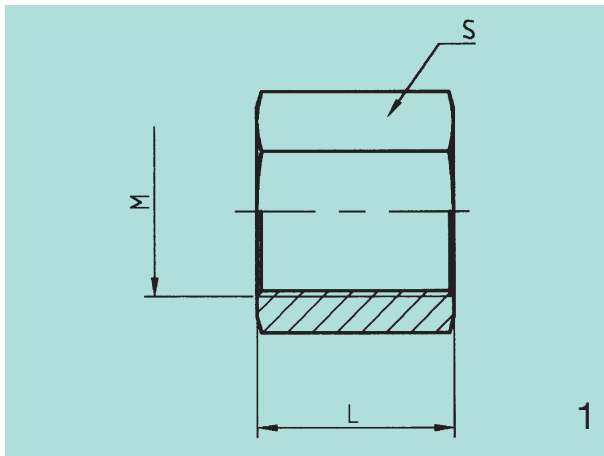

L	L ₁	S	M	M ₁	Bild pic.	Sach.-Nr. comp. no.	Artikel-Nr. part no.
L	L ₁	S	M	M ₁			
25	–	17	12x1,5	–	1	2376/21	MU25M12Dc3d
25	–	19	14x1,5	–	1	2377/21	MU25M14Dc3d
25	–	22	16x1,5	–	1	2378/21	MU25M16Dc3d
25	–	24	18x1,5	–	1	2379/21	MU25M18Dc3d
25	–	27	22x1,5	–	1	2380/21	MU25M22Dc3d
25	–	32	26x1,5	–	1	2382/21	MU25M26Dc3d
38	–	27	22x1,5	–	1	2381/21	MU38M22Dc3d
30	14	22	16x1,5	12x1,5	2	2383/21	MUM16M12Dc3d
30	14	27	22x1,5	16x1,5	2	2384/21	MUM22M16Dc3d
30	14	27	22x1,5	18x1,5	2	2385/21	MUM22M18Dc3d
30	14	27	22x1,5	G3/8A	2	2386/21	MUM22R3/8Dc3d
30	14	27	22x1,5	G1/2A	2	2387/21	MUM22R1/2Dc3d
32	14	27	22x1,5	NPT1/4	2	2597/21	MUM22NPT1/4Dc3d
35	20	32	26x1,5	22x1,5	2	2388/21	MUM26M22Dc3d

Hohlschrauben

Hollow screws

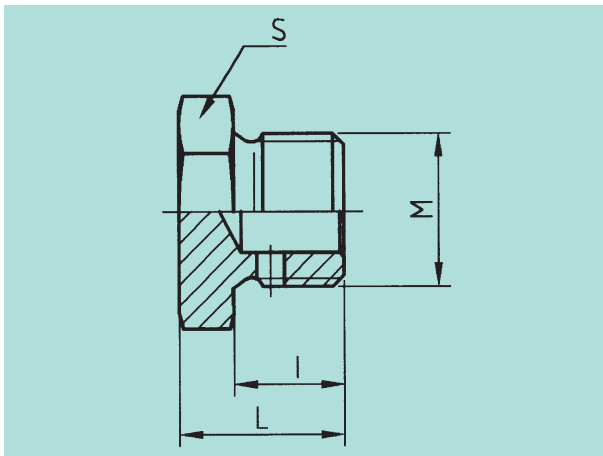

l	L	S	M	Sach.-Nr. comp. no.	Artikel-Nr. part no.
l	L	S	M		
12	19	27	22x1,5	2422/21	HS15D05c3d

Sechskantmuttern

Lock nuts

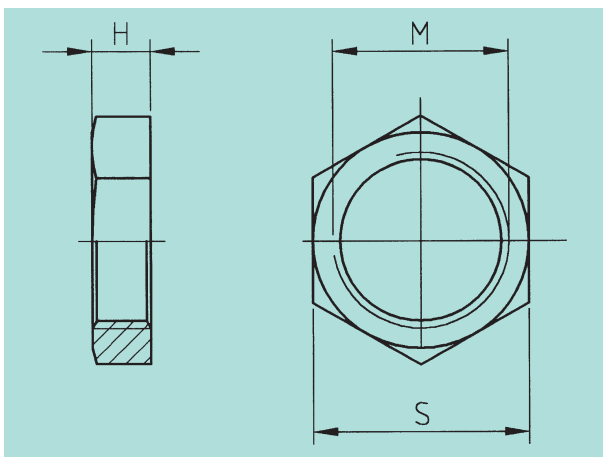

H	S	M	Sach.-Nr. comp. no.	Artikel-Nr. part no.
H	S	M		
6	17	12x1,5	2423/21	SKM12x1,5D705c3d
6	19	14x1,5	2425/21	SKM14x1,5D705c3d
6	22	16x1,5	2426/21	SKM16x1,5D705c3d
6	24	18x1,5	2427/21	SKM18x1,5D705c3d
8	36	26x1,5	2431/21	SKM26x1,5D705c3d
8	41	30x2	2432/21	SKM30x2D705c3d
8	27	22x1,5	2437/21	SKM22x1,5D305c3d
8	32	26x1,5	2438/21	SKM26x1,5D305c3d

Verschlusschrauben

Socket head port plugs

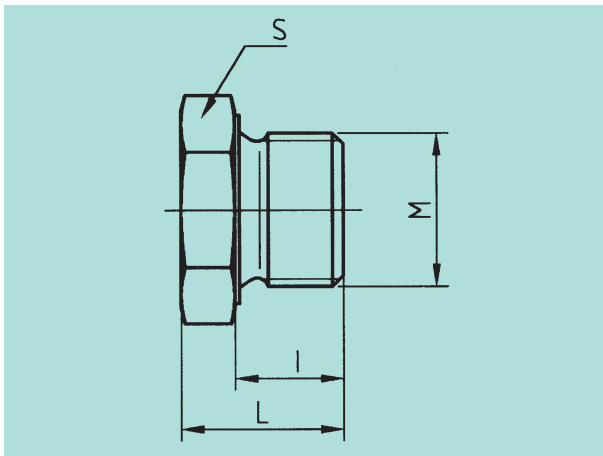

I	L	S	M	Sach.-Nr.	Artikel-Nr.
I	L	S	M	comp. no.	part no.
6	11,5	14	10x1	2439/21	VM10c3d
9	16,5	17	12x1,5	2440/21	VM12c3d
9	16,5	19	14x1,5	2441/21	VM14c3d
9	16,5	22	16x1,5	2442/21	VM16c3d
9	17	17	18x1,5	2443/21	VM18c3d
9	17	19	22x1,5	2444/21	VM22c3d
12	20	19	22x1,5	9925/21	VM22Sc3d
12	22,5	22	26x1,5	2445/21	VM26c3d

Überwurfmutter für Schlauchstutzen

Nuts for hose nozzles

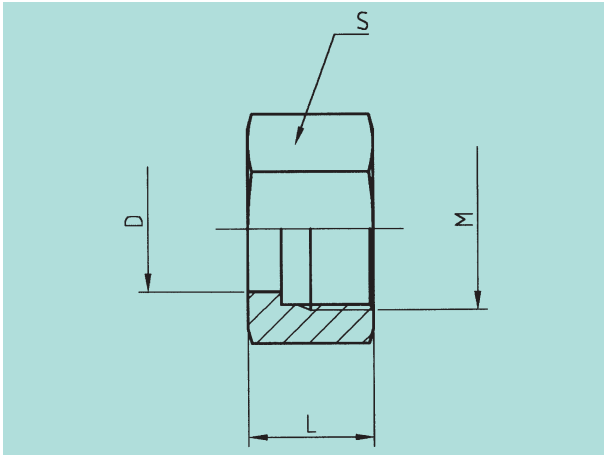

D	L	S	M	Sach.-Nr. comp. no.	Artikel-Nr. part no.
17	17	27	22x1,5	2454/22	M15B2LLc3dw

Überwurfmuttern

Nuts

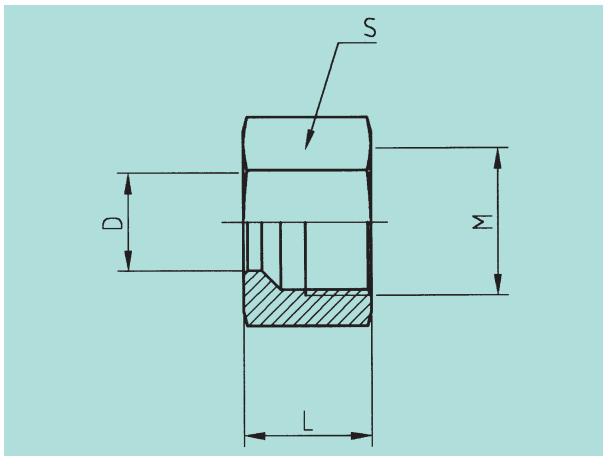

Alle Überwurfmuttern sind mit einer farblosen Gleichtbeschichtung behandelt.

All nuts with transparent antifriction coating.

D	L	S	M	Sach.-Nr.	Artikel-Nr.
D	L	S	M	comp. no.	part no.
6	14,5	14	12x1,5	743/22	M6Lc3dw
8	14,5	17	14x1,5	746/22	M8Lc3dw
10	15,5	19	16x1,5	748/22	M10Lc3dw
12	15,5	22	18x1,5	749/22	M12Lc3dw
15	17	27	22x1,5	750/22	M15Lc3dw
15	27	27	22x1,5	2460/22	M15Dc3dw
16	27	27	22x1,5	2461/22	M16Dc3dw
18	18	32	26x1,5	752/22	M18Lc3dw
18	27	32	26x1,5	2463/22	M18Dc3dw
22	20	36	30x2	753/22	M22Lc3dw

Druckringe

Thruststrings

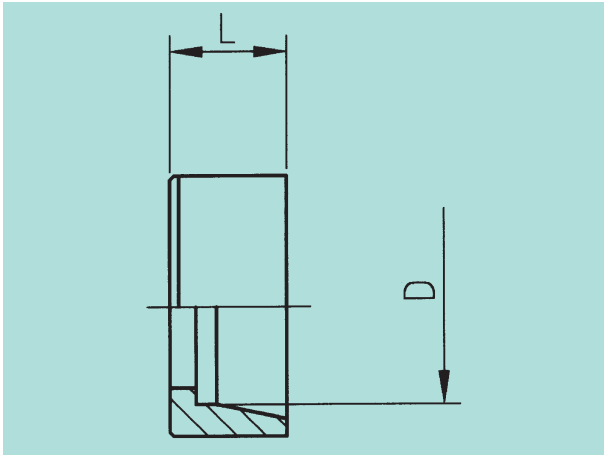

D	L	Sach.-Nr.	Artikel-Nr.
D	L	comp. no.	part no.
15	9	2465/21	DR15Dc3d
16	9	2466/21	DR16Dc3d
18	9	2467/21	DR18Dc3d

Schneidringe

Cutting rings

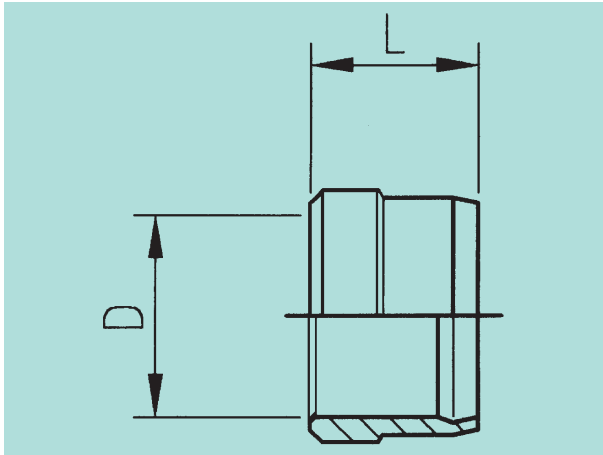

D	L	Sach.-Nr.	Artikel-Nr.	
D	L	comp. no.	part no.	
6	9,5	772/21	S6L/Sc3d	⁵⁾
8	9,5	774/21	S8L/Sc3d	⁵⁾
10	10	776/21	S10L/Sc3d	⁵⁾
12	10	777/21	S12L/Sc3d	⁵⁾
15	10	778/21	S15Lc3d	
16	9	2468/21	S16LLc3d	
18	10	779/21	S18Lc3d	
22	10,5	780/21	S22Lc3d	

Schneidringe Form A: Schneidringe mit 1 Schneide

Cutting form A: cutting with 1 edge

⁵⁾ Baureihe L+S sind baugleich

⁵⁾ series L+S are built the same way

Druckringe – Rundschnurringe

Thrustrings – O-rings

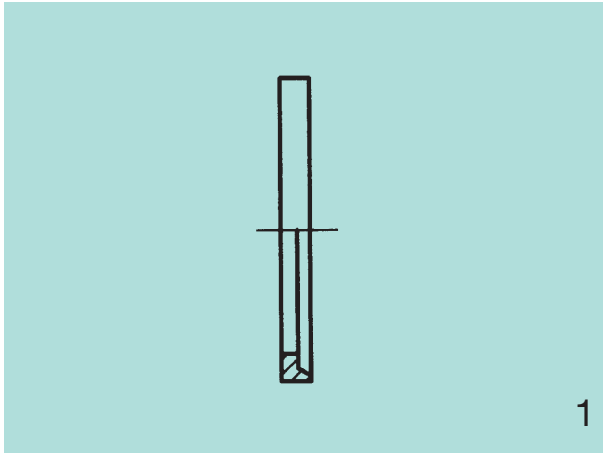

1

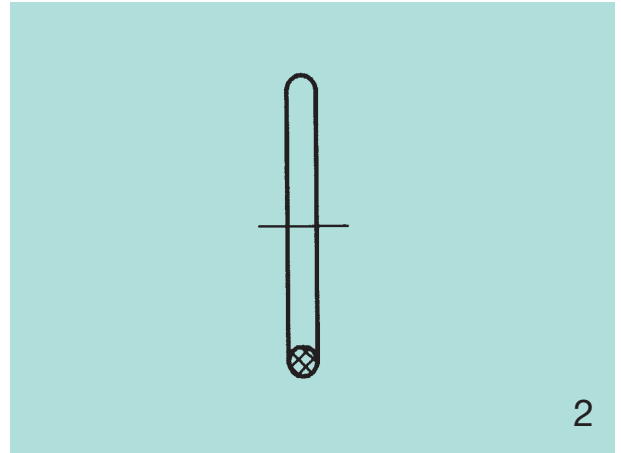

2

Für Einschraubgewinde for thread	Druckring 1 thrustring 1		Rundschnurring 2 O-ring 2		Druckring + Rundschnurring thrustring + O-ring	
	Sach.-Nr. comp. no.	Artikel-Nr. part no.	Sach.-Nr. comp. no.	Artikel-Nr. part no.	Sach.-Nr. comp. no.	Artikel-Nr. part no.
10x1	2488/50	DM10ms	2495/00	RM10	3032/50	DRM10ms
12x1,5	2489/50	DM12ms	2496/00	RM12	3033/50	DRM12ms
14x1,5	2490/50	DM14ms	2497/00	RM14	3034/50	DRM14ms
16x1,5	2491/50	DM16ms	2498/00	RM16	3035/50	DRM16ms
18x1,5	2492/50	DM18ms	2499/00	RM18	3036/50	DRM18ms
22x1,5	2493/50	DM22ms	2500/00	RM22	3037/50	DRM22ms
26x1,5	2494/50	DM26ms	2501/00	RM26	3038/50	DRM26ms

Druckring Werkstoff: Messing
Thrustring material: brass

Dichtringe

Sealing washers

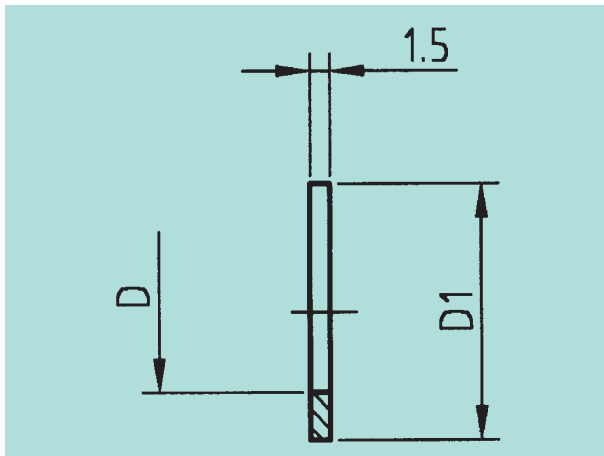

D	D ₁	für Rohr ø	Sach.-Nr.	Artikel-Nr.
D	D ₁	for tube ø	comp. no.	part no.
12	19	15	2471/00	FR15D
14	20	16	2473/00	FR16D
15	23	18	2475/00	FR18D

Flachdichtringe

Sealing washers

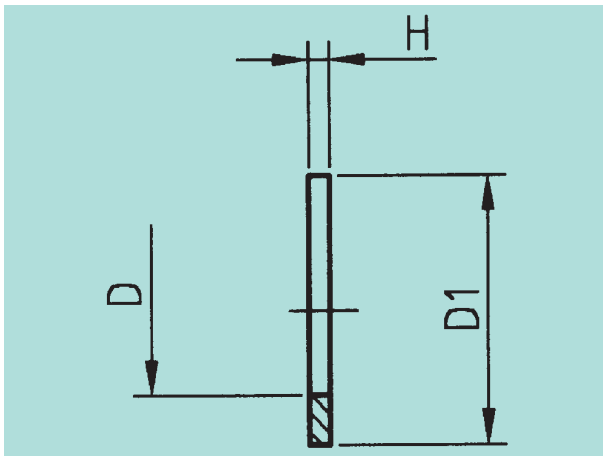

D	D ₁	H	Werkstoff material	für Einschraubgewinde for thread	Sach.-Nr. comp. no.	Artikel-Nr. part no.
10,2	13,5	1	Cu	10x1	2579/00	CRM10
12,2	15,4	1,5	Cu	12x1,5	2477/00	CRM12
14,2	19,9	1,5	Cu	14x1,5	2478/00	CRM14
16,2	21,9	1,5	Cu	16x1,5	2479/00	CRM16
18,2	21,9	1,5	Cu	18x1,5	2480/00	CRM18
22,2	26,9	1,5	Cu	22x1,5	2481/00	CRM22
26,3	30,9	2	Cu	M26x1,5/G3/4A	2482/00	CRM26/CRR3/4
27,3	31,9	2	Cu	27x2	2483/00	CRM27
10,2	13,5	1	Cu	G1/8A	2484/00	CRRR1/8
14,2	17,9	1,5	Cu	G1/4A	2485/00	CRR1/4
17,2	20,9	1,5	Cu	G3/8A	2486/00	CRR3/8
21,2	25,9	1,5	Cu	G1/2A	2487/00	CRR1/2

Werkstoff = Kupfer max. 45 HB
Material = Copper max. 45 HB

Stützhülsen – Messing

Sleeves

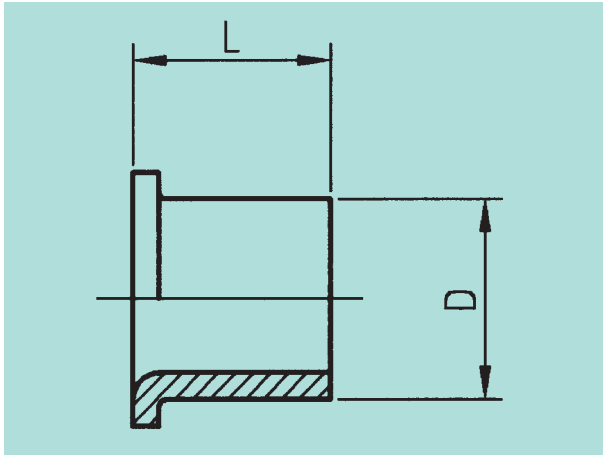

Für Rohr for tube	D D	L L	Sach.-Nr. comp. no.	Artikel-Nr. part no.
6x1	4	10	2502/50	SH6x1ms
8x1	6	15	2559/50	SH8x1ms
10x1	8	15	2560/50	SH10x1ms
10x1,25	7,5	15	2589/50	SH10x1,25ms
10x1,5	7	15	2586/50	SH10x1,5ms
12x1	8	15	2567/50	SH12x1ms
12x1,5	9	15	2561/50	SH12x1,5ms
15x1,5	12	15	2562/50	SH15x1,5ms
18x1,5	15	15	2563/50	SH18x1,5ms
18x2	14	15	2564/50	SH18x2ms

Werkstoff: Messing
Material: brass

Verstärkungshülsen für Stahlrohre siehe Hydraulikkatalog
Reinforcing sleeves for steeltubes see hydraulic katalog

Entwässerungsventile

Drain valves

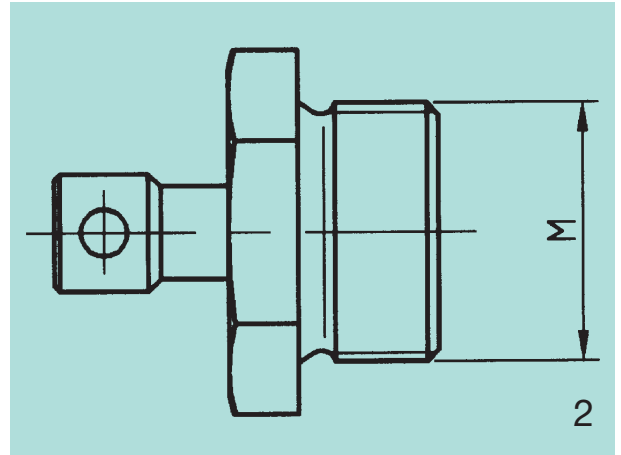
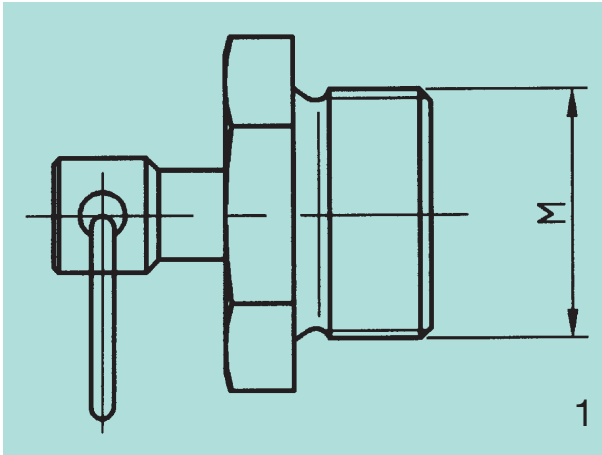

Ausführung type	M M	Bild pic.	Sach.-Nr. comp. no.	Artikel-Nr. part no.	DIN Nr./Bemerk. DIN no./remarks
mit Ring	22x1,5	1	3040/50	EV-C15D92m.R.ms	DIN 74292-C20
ohne Ring	22x1,5	2	3041/50	EV-B15D92ms	DIN 74292-B20

Werkstoff: Messing
Material: brass

Teile können mit kegeligem R1/2 oder M22x1,5 Gewinde geliefert werden
Supplied as well with taper thread R1/2 or M22x1,5

Prüfanschlüsse

Die nachfolgend aufgeführten Prüfanschlüsse sind nach DIN 74326 Form B (DIN/ISO 3538) gefertigt. Außer den aufgeführten Typen sind weitere Kombinationen möglich.

Prüfanschlüsse nach Form B werden serienmäßig mit Evoprene-Steckkappe geliefert. Werden andere Schutzkappen gewünscht, bitten wir dies bei der Bestellung anzugeben.

Sollten Sie dennoch für Ihren Bedarf oder spezielle Einbausituationen andere Prüfanschlüsse benötigen, setzen Sie sich mit uns in Verbindung, wir können Ihnen sicherlich eine Lösung anbieten.

Test set fittings

The following listed test set fittings are produced according DIN 74326 form B (DIN/ISO 3583). Besides the listed types further combinations are possible.

Test set fittings according from B will be normally delivered with a non threaded rubber Evoprene cap. Other caps are required (threaded plastic) please indicate in your order.

If special installations are required please contact us. We can certainly offer solutions.

Einschraubstutzen mit Prüfanschluss

Test set couplings

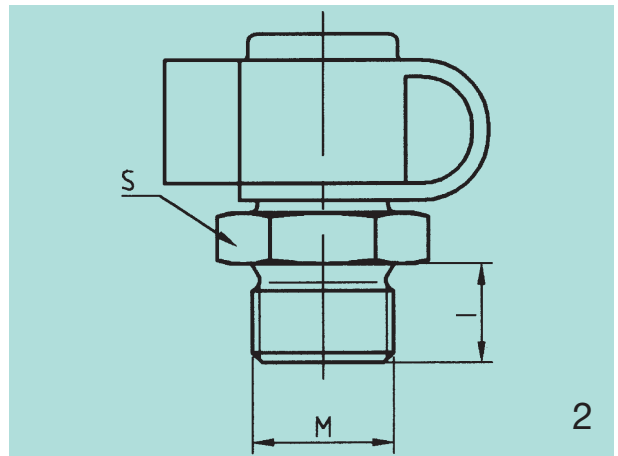
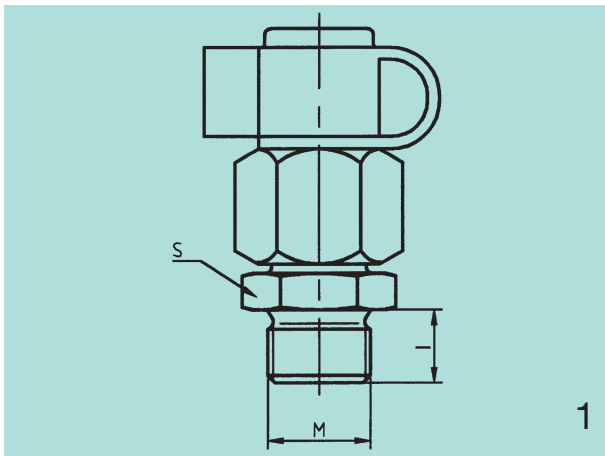

I	S	M	Bild	Sach.-Nr.	Artikel-Nr.
I	S	M	pic.	comp. no.	part no.
10	17	12x1,5	1	3061/21	M12D-PAc3d
10	19	14x1,5	1	3062/21	M14D-PAc3d
10	17	12x1,5	2	9173/50	EM12D-PAMs
12	22	16x1,5	2	3064/50	EM16D-PAMs
12	27	22x1,5	2	3093/50	EM22D-PAMs
15	17	NPT1/4	2	3092/21	ENPT1/4D-PAc3d

Prüfanschlüsse

Test sets

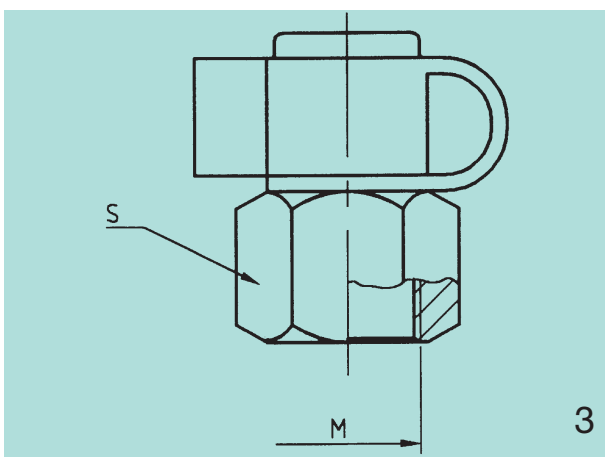

Artikel-Nr. PAM und EM = Werkstoff: Messing
Part no. PAM and EM = Material: brass

S	M	Sach.-Nr.	Artikel-Nr.
S	M	comp. no.	part no.
17	12x1,5	3068/50	PAM12ms
17	14x1,5	3069/50	PAM14ms
22	16x1,5	3070/50	PAM16ms
24	18x1,5	3072/50	PAM18ms
27	22x1,5	3074/50	PAM22ms

Gerade Einschraubverschraubungen

mit Prüfanschluss



Straight male couplings with test set couplings

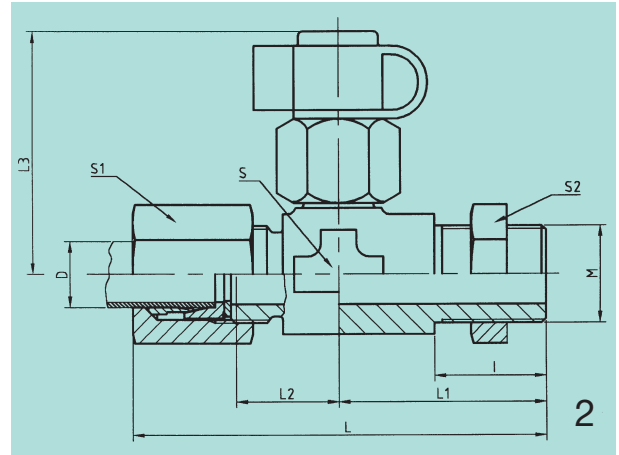
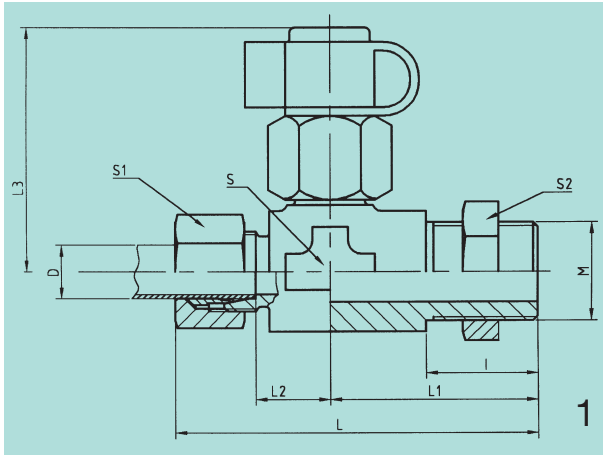

D	I	L	L ₁	L ₂	L ₃	S	S ₁	S ₂	M	Bild pic.	Sach.-Nr. comp. no.	Artikel-Nr. part no.
10	24	70	38	17	53	17	19	22	16x1,5	1	3043/21	GE10M16D-PAc3d
10	25	61	33	13	55	27	19	27	22x1,5	1	3042/21	GE10M22D-PAc3d
12	24	70	38	17	53	17	22	22	16x1,5	1	3044/21	GE12M16D-PAc3d
15	25	63	33	13	55	27	27	27	22x1,5	1	3045/21	GE15M22D-PAc3d
15	25	72	33	23	55	27	27	27	22x1,5	2	3106/21	GE15M22D99-PAc3d

Gerade Verschraubungen mit Prüfanschluss

Straight couplings with test set couplings

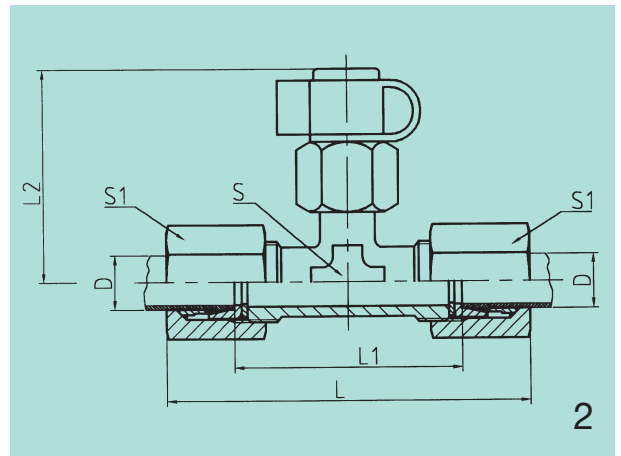
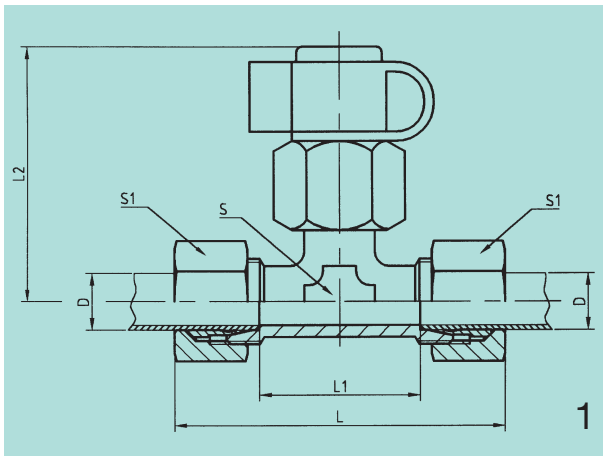

D	L	L ₁	L ₂	S	S ₁	Bild pic.	Sach.-Nr. comp. no.	Artikel-Nr. part no.
6	54	24	54	12	14	1	3055/21	G6-PAc3d
8	58	28	54	12	17	1	3056/21	G8-PAc3d
10	60	30	55	14	19	1	3094/21	G10-PAc3d
12	64	34	55	17	22	1	3057/21	G12-PAc3d
15	72	42	58	19	27	1	3058/21	G15-PAc3d
15	95	62	58	19	27	2	3059/21	G15D-PAc3d

T-Verschraubungen mit Prüfanschluss

Tee couplings with test set couplings

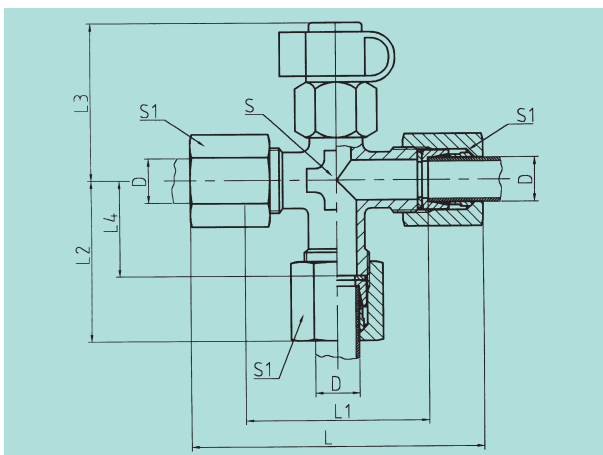

D	L	L ₁	L ₂	L ₃	L ₄	S	S ₁	Sach.-Nr. comp. no.	Artikel-Nr. part no.
15	109	36	62	55	45	19	27	3060/21	T15D-PAc3d

¹⁾ Nur auf Anfrage

¹⁾ Supplied on request

Winkel-Verschraubungen mit Prüfanschluss

Elbow couplings with test set couplings

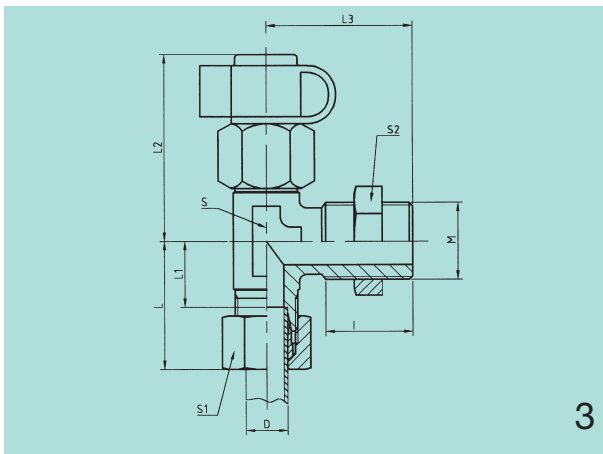
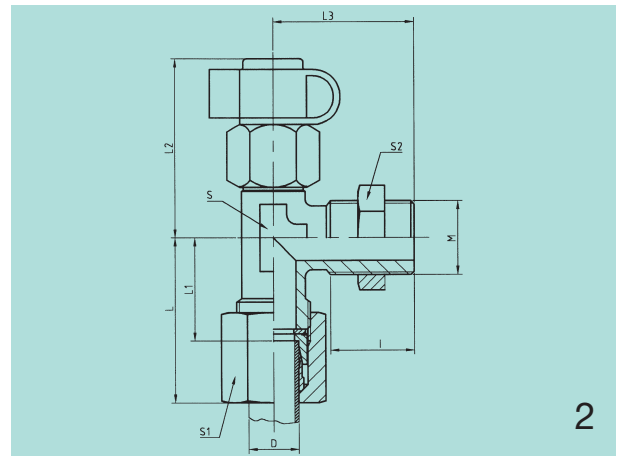
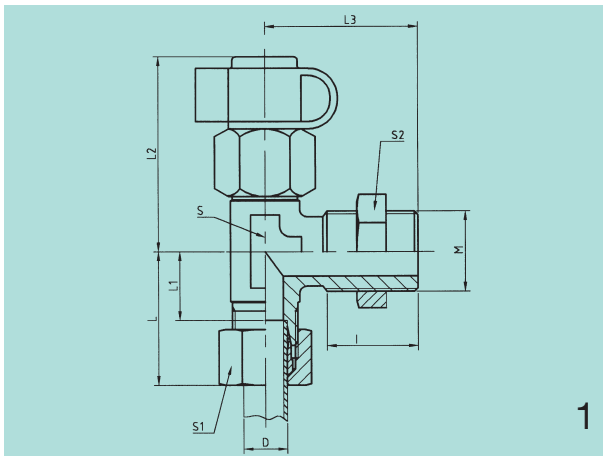

D	I	L	L ₁	L ₂	L ₃	S	S ₁	S ₂	M	Bild pic.	Sach.-Nr. comp. no.	Artikel-Nr. part no.
8	21	30	15	54	38	17	17	22	16x1,5	1	3046/21	WE8M16D-PAc3d
10	21	32	17	54	38	17	19	22	16x1,5	1	3047/21	WE10M16D-PAc3d
10	25	36	21	54	45	17	19	27	22x1,5	1	3048/21	WE10M22D-PAc3d
12	21	32	17	54	38	17	22	22	16x1,5	1	3049/21	WE12M16D-PAc3d
12	25	36	21	54	45	17	22	27	22x1,5	1	3050/21	WE12M22D-PAc3d
15	25	36	21	54	45	19	27	27	22x1,5	1	3051/21	WE15M22D-PAc3d
15	25	49	34	54	45	19	27	27	22x1,5	2	3122/21	WE15M22D01-PAc3d
-	24	42	-	54	42	19	27	-	22x1,5	3	3054/21	WEM22M22D-PAc3d

³⁾ Ausführung mit oder ohne Bund nach unserer Wahl

³⁾ Design with or without collar like our choice